

GOIZPER

YOUR PARTNER
IN POWER TRANSMISSION

PNEUMATIC CLUTCH-BRAKES

FRENO-EMBRAGUES NEUMÁTICOS



GOIZPER

YOUR PARTNER
IN POWER TRANSMISSION

INTRODUCTION		4
TECHNICAL INFORMATION		6
CLUTCH-BRAKE	SERIES 5.8	17
CLUTCH-BRAKE	SERIES 5.7	25
CLUTCH-BRAKE	SERIES 5.0	33
CLUTCH-BRAKE	SERIES 5.5 and 5.6	41
ACCESSORIES		47
PNEUMATIC CLUTCHES	SERIES 5.35	50
PNEUMATIC SAFETY BRAKES	SERIES 5.36	51
WET CLUTCH-BRAKE	SERIES 5.W	53
SPECIAL CLUTCH-BRAKE UNITS		57
QUESTIONNAIRE		58

INTRODUCCIÓN		4
INFORMACIÓN TÉCNICA		6
FRENO-EMBRAGUE	SERIE 5.8	17
FRENO-EMBRAGUE	SERIE 5.7	25
FRENO-EMBRAGUE	SERIE 5.0	33
FRENO-EMBRAGUE	SERIE 5.5 y 5.6	41
ACCESORIOS		47
EMBRAGUES NEUMÁTICOS	SERIE 5.35	50
FRENOS NEUMÁTICOS DE SEGURIDAD	SERIE 5.36	51
FRENO-EMBRAGUES OLEONEUMÁTICOS	SERIE 5.W	53
FRENO-EMBRAGUES ESPECIALES		57
CUESTIONARIO		58

INTRODUCTION

GOIZPER is a leading technology company offering power transmission component solutions. This catalogue shows their latest range of Pneumatic Clutches, Brakes, Clutch-Brakes, Wet Clutch-Brakes, Spring Engaged Safety Brakes and Accessories.

This range of products can be used in a diverse market: machinery for cutting and welding metal, presses, shears, folding, construction sector, marine...

The clutch-brakes are single piston double functioning that engage the clutch and brake without overlapping their engagement. Depending upon customer requirements we offer many solutions - combinations, multiple disc clutches, safety, hydraulic, etc...

INTRODUCCIÓN

Goizper, empresa referente tecnológica en ofrecer soluciones diferenciales de componentes de transmisión de potencia, presenta en este catálogo la gama más completa y tecnológica de Frenos, Embragues, Freno-Embragues Neumáticos, Freno-Embragues Oleoneumáticos y sus Accesorios.

Los ámbitos de aplicación de esta gama de productos son diversos: maquinaria para corte y deformación metálica, prensas, cizallas, plegadoras, ámbito de la construcción, marino...

Los freno-embragues son sistemas con doble función de frenado y embragado, no pudiendo estar ambas funciones activadas al mismo tiempo. En función de las necesidades y requerimientos de cada cliente, se ofrecen Combinados, Multidisco, De Seguridad, Oleoneumáticos ...

PRODUCT RANGE PNEUMATIC CLUTCH - BRAKES / FRENO - EMBRAGUES NEUMATICOS

Combined / Combinados



SERIES 5.8



SERIES 5.7



SERIES 5.0



SERIES 5.5



SERIES 5.6

Separated / Separados



SERIES 5.35



SERIES 5.36

Wet Clutch Brakes / Oleoneumáticos



SERIES 5.W

Accessories / Accesorios



AIR INLET DISC
DISCO ALIMENTACIÓN
LATERAL



AIR ROTARY UNION
RACOR GIRATORIO

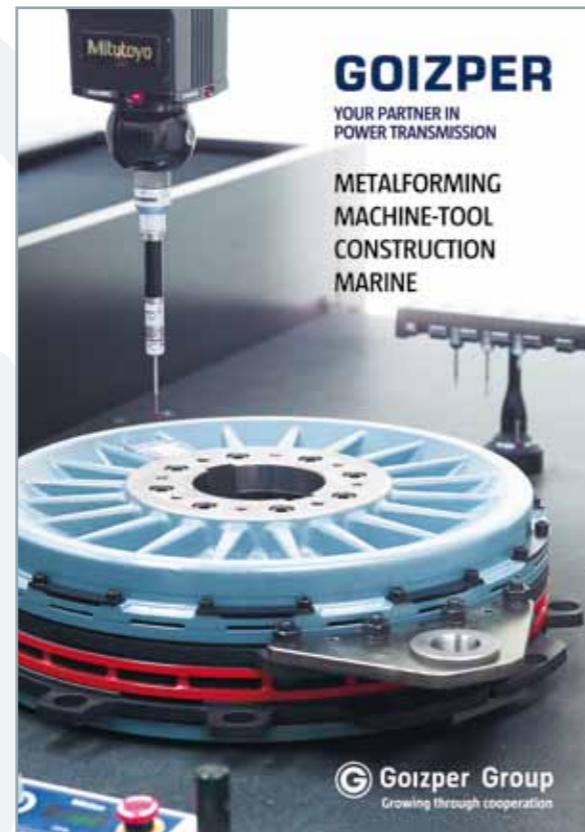

TECHNICAL INFORMATION

This chapter explains the basic concepts and formulas for the calculation and selection of clutch-brakes for each application.

All the formulas used in this catalogue are in accordance with VDI 2241 and/or DIN 1304 norm.

For further assistance please contact our technical department.

DEFINITIONS

TORQUES

It is important to define and differentiate the torques considered in the clutching or braking process.

The torque values shown in graph 1 are defined below.

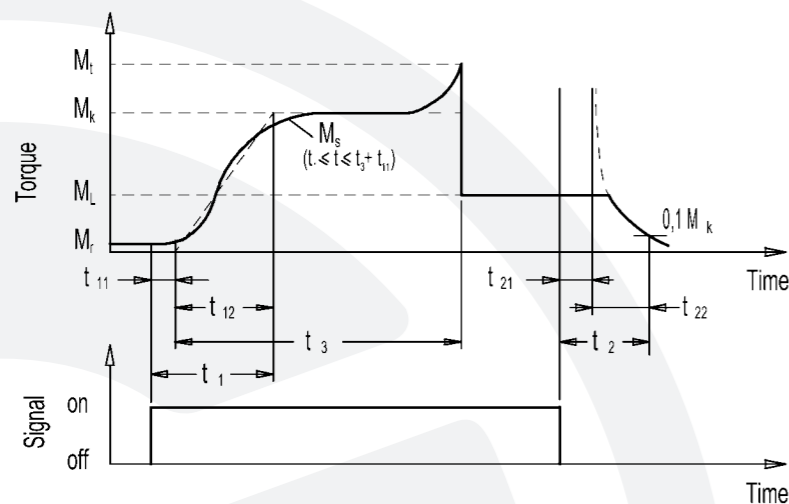

Graph 1

Slip or dynamic torque M_s : this is the torque transmitted once the torque increase time (t_{12}) is finished. It changes within the cycle process and depends, apart from other factors, on the slip speed and the temperature of the friction surfaces.

Transmissible torque or static torque M_t : maximum admissible torque without slip, depending on the working and design conditions.

INFORMACIÓN TÉCNICA

En este apartado se definen y explican los conceptos y fórmulas básicos necesarios para el cálculo y selección de los freno-embragues adecuados para cada aplicación.

Las designaciones, símbolos en las fórmulas y las unidades utilizadas en este catálogo siguen las normas VDI 2241 y / o la DIN1304, normas de referencia para este tipo de productos.

En caso de cualquier duda, aclaración o interés en algún aspecto concreto, les rogamos se pongan en contacto con nuestro departamento técnico.

DEFINICIONES

PARES

Primeramente es importante definir y distinguir los distintos momentos o pares que se consideran en un proceso de embragado o frenado.

El siguiente gráfico representa a cualquiera de dichos procesos:

Par de deslizamiento o par dinámico M_s : par que actúa una vez finalizado el tiempo de subida de par (t_{12}). Varía durante el proceso de maniobra y depende, entre otros factores, de la velocidad de deslizamiento y la temperatura de las superficies de fricción.

Par transmisible o par estático M_t : par máximo que admite el sistema actuado en función de las condiciones de servicio y las condiciones marginales del diseño, sin que se produzca resbalamiento.

Residual torque M_r : torque transmitted when the system is not actuated. It depends on mounting position, (horizontal, vertical, or inclined), speed related to disc surface, oil flow, & viscosity.

When vertical or inclined mounting, the residual torque increases very much, so the generated heat is increased as well.

Loading torque M_L : necessary torque to activate the elements in the machine, taking into account its performance, the action speed, etc.

Characteristical torque M_k : It is the torque indicated in the catalogue.

Acceleration torque M_a (deceleration torque when the value is negative): torque necessary to accelerate in time t. Usually equal to dynamic torque.

This torque is calculated by using the following formulation:

$$M_a = \frac{J (n_{10} - n_{20})}{9,56 \cdot t} \quad (\text{Nm})$$

Being:

J : moment of inertia (kgm^2).
 n_{10} : driver shaft speed (r.p.m.).
 n_{20} : driven shaft speed (r.p.m.).
t : time (s).
 M_a : acceleration torque (Nm).

FRICITION COEFFICIENTS

To calculate different torques, the following coefficients are considered.

μ : Slipping or dynamic friction coefficient.
 μ_0 : Static friction coefficient.

The ratio between both coefficients for the different materials will be indicated in next chapters.

Par residual M_r : par que transmite el sistema cuando no está actuado. Depende de su posición (horizontal, vertical o inclinado), la velocidad relativa de las superficies de las láminas o discos, de la viscosidad del aceite y caudal del mismo en caso de que el sistema trabaje en aceite.

En caso de montaje vertical o inclinado el par residual se incrementa de forma importante aumentando el calor generado.

Par de carga M_L : par necesario para accionar los elementos de la máquina teniendo en cuenta su rendimiento, la velocidad de accionamiento, etc.

Par característico M_k : par indicado en el catálogo.

Par de aceleración M_a (par de deceleración cuando el valor numérico es negativo): par necesario para la aceleración de las masas en un tiempo concreto.

Dicho par se calcula por la fórmula:

$$M_a = \frac{J (n_{10} - n_{20})}{9,56 \cdot t} \quad (\text{Nm})$$

Siendo:

J : momento de inercia (kgm^2).
 n_{10} : velocidad del eje conductor (r.p.m.).
 n_{20} : velocidad del eje conducido (r.p.m.).
t : tiempo (s).
 M_a : par de aceleración (Nm).

COEFICIENTES DE FRICCIÓN

Para el cálculo de los distintos pares, se considerarán en este catálogo los siguientes coeficientes.

μ : Coeficiente de fricción dinámico o de deslizamiento.

μ_0 : Coeficiente de fricción estático o de adherencia.

La relación entre ambos coeficientes para los distintos materiales se indicará en apartados posteriores.

TIME TERMS IN THE TORQUE TRANSMISSION

Like in the torques, it is important to define different times existing in the torque transmission that appear in graph 1, which are:

Reaction delay t_{11} : time from the activation of the control until the beginning of the torque increase.

Rising time t_{12} : time from the beginning of the torque increase until reaching the stationary condition.

Link time t_1 : sum up of the reaction delay time and the rising time.

$$t_1 = t_{11} + t_{12}$$

Slip time t_3 : time of relative movement between friction surfaces of an actuated mechanism.

Total time t_t : Time from the signal until the torque transmission is accomplished.

$$t_t = t_{11} + t_3$$

TIME TERMS FOR INTERRUPTING THE TORQUE TRANSMISSION (GRAPH 1)

We define the torque transmission interruption times in a similar way than we have done in the previous paragraph.

Reaction time when interrupting the transmission t_{21} : Time from the deactivation of the control until the beginning of the torque decrease.

Decrease torque t_{22} : Time from the torque decrease until reaching 10% of the characteristic torque.

Disconnection time t_2 : Sum up of the reaction delay and the decrease time.

$$t_2 = t_{21} + t_{22}$$

TÉRMINOS DE TIEMPO PARA ESTABLECER LA TRANSMISIÓN DEL PAR

De la misma forma que en el caso de los pares, es importante definir los diferentes tiempos existentes en el proceso de transmisión del par, y que aparecen reflejados en el gráfico 1. Estos son:

Retardo de reacción al establecer la transmisión t_{11} : tiempo desde la activación del mando hasta el comienzo de la subida del par.

Tiempo de subida t_{12} : tiempo desde el comienzo de la subida del par hasta alcanzar el estado cuasi estacionario.

Tiempo de enlace t_1 : tiempo resultante de la suma del retardo de reacción y el tiempo de subida.

$$t_1 = t_{11} + t_{12}$$

Tiempo de deslizamiento t_3 : tiempo durante el cual tiene lugar un movimiento relativo entre las superficies de fricción de un mecanismo actuado.

Tiempo total t_t : tiempo desde que se da la señal hasta que se completa la transmisión del par.

$$t_t = t_{11} + t_3$$

TÉRMINOS DE TIEMPO PARA INTERRUPTIR LA TRANSMISIÓN DEL PAR (GRÁFICO 1)

Similarmenete a lo indicado en el apartado anterior, se definen los distintos tiempos existentes en el proceso de interrupción de la transmisión de par.

Retardo de reacción al interrumpir la transmisión t_{21} : tiempo desde la desactivación del mando hasta el comienzo de la caída del par.

Tiempo de caída t_{22} : tiempo desde el comienzo de la caída del par hasta alcanzar el 10 % del par característico.

Tiempo de desconexión t_2 : suma del retardo de reacción y el tiempo de caída.

$$t_2 = t_{21} + t_{22}$$

MOMENT OF INERTIA J

It is important to consider the moment of inertia "J" before making the following calculations.

For example, the moment of inertia of a solid iron cylinder which is 100mm thick with an outer diameter D (in mm) is obtained with the following formulation:

$$J = 77 \cdot D^4 \text{ (kgm}^2\text{)}$$

When the moment of inertia is not referred to the clutch shaft, it is necessary to reduce it to this shaft. The following formulation is used.

$$J_{red} = J \cdot i^2 \text{ (kgm}^2\text{)}$$

J : moment of inertia of the shaft masses at any speed. (kgm²).

J_{red} : moment of inertia reduced to the clutch shaft (kgm²).

i : speed ratio between shafts.

$$i = \frac{n_2}{n_1}$$

n_1 : clutch speed (r.p.m.).

n_2 : speed of the shaft with inertia J (r.p.m.).

If the masses to accelerate have a lineal movement, their moments of inertia are reduced to the clutch shaft as per the following formulation:

$$J_{red} = 91 \cdot m \cdot \frac{v^2}{n^2} \text{ (kgm}^2\text{)}$$

m : masses in lineal movement (kg).

v : speed of the mentioned masses (m/s).

J_{red} : moment of inertia reduced to the clutch shaft (kgm²).

THERMAL CAPACITY

Concerning the heat transmission, the following concept is defined:

Work per engagement Q: It is the energy caused by friction and transformed into heat, as a consequence of engaging.

$$Q = \frac{J \cdot (n_{10} \pm n_{20})^2}{182,4 \cdot 10^3} \cdot \frac{M_k}{M_k \pm M_L} \text{ (kJ)}$$

J : moment of inertia (kgm²).

M_k : transmissible torque (Nm).

M_L : loading torque (Nm).

n_{10} : Speed drive (min⁻¹).

n_{20} : Speed drive (min⁻¹).

MOMENTO DE INERCIA J

Es importante para los distintos cálculos que se indican posteriormente considerar el concepto de momento de inercia "J".

Así por ejemplo, el momento de inercia de un cilindro macizo de hierro de 100 mm de espesor, siendo su diámetro exterior D (en m), se obtiene de la fórmula:

$$J = 77 \cdot D^4 \text{ (kgm}^2\text{)}$$

Cuando el momento de inercia no está referido al eje del embrague, es necesario reducirlo a dicho eje. Para ello se utiliza la siguiente fórmula:

$$J_{red} = J \cdot i^2 \text{ (kgm}^2\text{)}$$

J : momento de inercia de las masas de un eje a una velocidad cualquiera (kgm²).

J_{red} : momento de inercia reducido al eje del embrague (kgm²).

i : relación de velocidades entre los ejes.

$$i = \frac{n_2}{n_1}$$

n_1 : velocidad del embrague (r.p.m.).

n_2 : velocidad del eje con inercia J (r.p.m.).

Si las masas a acelerar tienen un movimiento lineal, sus momentos se reducen al eje del embrague, por la siguiente fórmula:

$$J_{red} = 91 \cdot m \cdot \frac{v^2}{n_1^2} \text{ (kgm}^2\text{)}$$

m : masas en movimiento lineal (kg).

v : velocidad de las citadas masas (m/s).

J_{red} : momento de inercia reducido al eje del embrague (kgm²).

CAPACIDAD CALORÍFICA

Desde el punto de vista de transmisión de calor se define el siguiente concepto:

Trabajo de maniobra Q: energía transformada en calor por la fricción a consecuencia de la maniobra.

$$Q = \frac{J \cdot (n_{10} \pm n_{20})^2}{182,4 \cdot 10^3} \cdot \frac{M_k}{M_k \pm M_L} \text{ (kJ)}$$

J : momento de inercia (kgm²).

M_k : par característico (Nm).

M_L : par de carga (Nm).

n_{10} : Unidad de velocidad (min⁻¹).

n_{20} : Unidad de velocidad (min⁻¹).

The work produced by each cycle, which is transformed into heat, must be removed without surpassing the thermal capacity of the clutch-brake.

In the pneumatic clutch-brakes the heat is absorbed by the elements of the clutch-brake and transmitted to the air by the surfaces that are in contact with the atmosphere.

In the hydraulic clutch-brakes, the heat is dissipated by means of lubrication oil. Lubrication can be done by splash, but when an intense work is required a forced cooling will be necessary, and lubrication will be done through the clutch-brake.

PERFORMANCE OF FRICTION MATERIALS

Depending on various factors, detailed below, the friction coefficient can change during the clutch or brake engagement. These factors also affect when the torque is transmitted with relative movement among the friction surfaces:

- Transmitted power.
- Temperature on the friction surfaces (cooling system).
- Slip speed.
- Combination of friction materials.
- Dry or wet operation.
- Design of the friction surfaces (grooves...).
- Pressure in the friction surfaces.
- Ambient temperature.
-

The combinations of materials used in our clutch-brakes are the following:

TYPE OF CLUTCH-BRAKE TIPO DE FRENO-EMBRAGUE	RUNNING MEDIO	COMBINATION OF MATERIALS COMBINACIÓN DE MATERIALES
Pneumatic Neumático	Dry Seco	Steel, cast iron / organic material Acero, hierro fundido / guarnición orgánica
Hydraulic-Wet Hidráulico-Oleoneumático	Wet En aceite	Tempered steel / sintered bronze Acero templado / sinterizado de bronce

El trabajo producido en cada maniobra, que se transforma en calor, debe ser evacuado sin sobrepasar la capacidad calorífica del frenoembrague.

En los freno-embragues neumáticos el calor es absorbido por los elementos del frenoembrague y transmitido al aire por las superficies que están en contacto con la atmósfera.

En los freno-embragues hidráulicos el calor es disipado fundamentalmente por medio del aceite de refrigeración. La lubricación puede realizarse por barboteo, aunque en los casos de un trabajo intenso será necesaria una refrigeración forzada, para lo cual la refrigeración se hará por el interior del frenoembrague.

COMPORTAMIENTO DE LOS ELEMENTOS DE FRICCIÓN

La variación del coeficiente de fricción durante la maniobra de embragado (o frenado), así como cuando se transmite el par sin movimiento relativo entre las superficies de fricción, depende de numerosos factores, entre los cuales podemos destacar:

- Potencia transmitida.
- Temperatura en las superficies de fricción (sistema de refrigeración).
- Velocidad de deslizamiento.
- Combinación de materiales de fricción.
- Funcionamiento en seco o lubricado.
- Diseño de las superficies de fricción (canales, espirales...)
- Presión en la superficie de fricción.
- Temperatura del entorno.
-

A continuación se indican las combinaciones de materiales utilizados habitualmente en nuestros freno-embragues:

PNEUMATIC CLUTCH-BRAKES:

These clutch-brakes work in dry condition and therefore the friction materials are casting or steel against organic asbestos-free material.

The friction surfaces are flat and the organic linings are bonded to the discs, leaving some radial slots free that permit the removal of contaminants and heat. Organic friction blocks can also be used.

For a proper performance, the friction surfaces should be free from grease and oil.

FRICCIÓN COEFFICIENT

High friction coefficients are obtained (0,35 to 0,45) with this combination of friction materials. In this case, there are no large differences between the dynamic and static friction coefficients.

WEAR OF THE LININGS

Linings suffer wear. Wear is low when the temperature of the metallic elements of the clutch-brake that are in contact with the lining do not exceed a temperature of 170°C. Above this temperature, wear increases considerably.

It is important to take into account the atmosphere temperature where the clutchbrake works, as well as its position in the machine. There must be enough space to permit the flow of fresh air at the clutch-brake.

THERMAL CHARACTERISTICS

Organic linings are rated for 350°C. Higher temperatures in short periods can be admissible but will incur in high wear.

The dissipation capacity with constant cycling can be between 0,7-1,4 J/mm² min depending on the factors indicated in the above heading called "performance of friction materials".

The energy produced per cycle and per surface of the unit should not exceed 2J/mm², consideration that will also be taken into account when working in continuous mode.

FRENO-EMBRAGUES NEUMÁTICOS:

Dichos freno-embragues trabajan en seco, siendo los elementos de fricción acero o fundido frente a guarnición orgánica sin amianto.

En este tipo de freno-embragues las superficies de fricción son lisas pero las guarniciones orgánicas van pegadas a los discos porta-guarniciones dejando entre sí unas ranuras radiales que sirven para la evacuación del abrasivo y del calor. También se pueden utilizar tacos de guarnición orgánica alojados en los discos porta-tacos.

Es necesario mantener las superficies de fricción limpias de grasa y aceite para un correcto funcionamiento.

COEFICIENTE DE FRICCIÓN

Con esta combinación de materiales de fricción se obtienen elevados coeficientes de fricción (0,35 a 0,45) sin grandes diferencias entre el coeficiente dinámico y el estático.

DESGASTE DE LAS GUARNICIONES

Las guarniciones están siempre sometidas a desgaste. Este desgaste es bajo, siempre que la temperatura de los elementos metálicos del frenoembrague que contactan con las guarniciones no superen aproximadamente 170 °C. Por encima de esta temperatura el desgaste aumenta considerablemente.

Es importante tener en cuenta la temperatura ambiente del lugar donde trabaja el frenoembrague y su ubicación en la máquina, que debe estar provista de suficiente espacio y medios que permitan la entrada libre de aire fresco a la zona.

CARACTERÍSTICAS TÉRMICAS

Las guarniciones orgánicas pueden admitir puntualmente temperaturas de hasta 350°C. Temperaturas más elevadas en periodos muy cortos de tiempo pueden ser admisibles a costa de un desgaste muy elevado.

El poder de disipación con cadencia constante de maniobras puede estar entre 0,7-1,4 J/mm² min dependiendo de los factores señalados en el apartado anterior "comportamiento de los elementos de fricción".

Además la energía producida por operación y por unidad de superficie no deberá pasar de 2J/mm², consideración que también se tendrá en cuenta cuando el funcionamiento es en continuo.

WET OPERATING HYDRAULIC CLUTCH-BRAKE:

Designed for wet operation, using tempered steel against sintered bronze.

The friction surfaces have been designed with grooves, taking into account (among other factors) the thermal load, the friction coefficient and the lubrication oil flow.

FRICITION COEFFICIENT

With this combination of friction materials, the following relation between the static and dynamic friction coefficient is obtained:

$$\frac{\mu_0}{\mu} = 1,7$$

WEAR OF THE SINTERED DISCS

Wear in this kind of combination is very low. It is important to assure appropriate lubrication of the friction surfaces and also to change oil regularly.

THERMAL CHARACTERISTICS

The sintered discs have a very good thermal conductivity that allow temperatures up to 350 °C approx (depending on slipping time).

The lubrication means in the friction surfaces have a big influence in the heat dissipation produced in each operation. The most common values are the following:

Splash lubrication: 0,7-1 J/mm²min
Forced lubrication: 1-2 J/mm²min

The energy produced per operation and per surface unit cannot exceed 1-2 J/mm² (VDI 2241).

FRENO-EMBRAGUES HIDRÁULICOS:

Diseñados para trabajo en aceite, emplean superficies de acero templado frente a sinterizado de bronce.

En este caso, las superficies de fricción han sido diseñadas con ranuras radiales y en espiral teniendo en cuenta entre otros factores, la carga térmica, el coeficiente de fricción, y el caudal de aceite de lubricación.

COEFICIENTE DE FRICCIÓN

Con esta combinación de materiales de fricción se obtiene una relación entre coeficiente de fricción estático y dinámico de aproximadamente:

$$\frac{\mu_0}{\mu} = 1,7$$

DESGASTE DE LAS LÁMINAS SINTERIZADAS

El desgaste en este tipo de combinación es muy reducido. Para ello, es esencial asegurar una adecuada lubricación de las superficies de fricción y también es importante cambiar el aceite regularmente.

CARACTERÍSTICAS TÉRMICAS

Las láminas sinterizadas tienen muy buena conductividad térmica lo que les permite soportar temperaturas de hasta 350°C aproximadamente.

En la disipación del calor producido en cada operación influye considerablemente el medio de lubricación de las superficies de fricción. Los valores más usuales son los siguientes:

Lubricación por barboteo: 0,7-1 J/mm²min
Lubricación forzada: 1-2 J/mm²min

Además la energía producida por operación y por unidad de superficie no deberá pasar de 1-2 J/mm² (VDI 2241).

BRAKING PROCESS

To calculate the slip time during the brake engagement t_3 , the following formula is used:

$$t_3 = \frac{t_{12}}{2} + k \cdot \frac{J \cdot w}{M_k} \text{ (S)}$$

t_{12} : Time of torque increase.
 k : Correction coefficient.
 J : Inertia referred to clutch-brake shaft (kgm²).
 w : Angular speed of clutch-brake (rad/s).
 M_k : Brake torque indicated in the catalogue (Nm).

In the case of the pneumatic clutch-brake units t_{12} is very variable, depending on the series, sizes, torque rates and pneumatic circuit (2 - 80 ms.).

In the case of the hydraulic ones, this value is inconsiderable.

The K coefficient is function of the factors indicated in chapter "performance of friction materials"

Its value is variable, considering for calculation $k= 1,25$ for both, pneumatic and hydraulic clutch-brake units.

The total braking time will therefore be:

$$t_t = t_{11} + t_3$$

t_{11} : is also variable in both, pneumatic and hydraulic clutch-brake units

BRAKING ANGLE θ_f

The braking angle can be divided in two terms:

- 1.- Reaction angle: $\theta_r = w \cdot t_{11}$
- 2.- Mechanical braking angle (θ_m):

$$\theta_m = f(M, J, w, t_{12}, t_3)$$

$$\theta_f = \theta_r + \theta_m$$

To simplify the calculation, the following formulation can be used:

$$\theta_f = w \cdot t_{11} + \frac{w}{2} \cdot t_3 \text{ (rad) or}$$

$$\theta_f = 6 \cdot n \cdot t_{11} + 3 \cdot n \cdot t_3 \text{ (}^\circ\text{)}$$

n : Clutch-brake rotational speed (r.p.m.).

PROCESO DE FRENADO

Para el cálculo del tiempo de deslizamiento durante el proceso de frenado t_3 , se emplea la siguiente fórmula:

$$t_3 = \frac{t_{12}}{2} + k \cdot \frac{J \cdot w}{M_k} \text{ (S)}$$

t_{12} : Tiempo de subida de par.
 k : Coeficiente de corrección.
 J : Inercias reducidas al eje del freno-embrague (kgm²).
 w : Velocidad angular del freno-embrague (rad/s).
 M_k : Par de freno de catálogo (Nm).

En el caso de los freno-embragues neumáticos, el tiempo de subida t_{12} es muy variable en función del tipo, tamaño, combinación de muelles y circuito neumático (2 - 80 ms.).

En el caso de los hidráulicos sin embargo, es prácticamente despreciable.

El coeficiente K es función de los factores mostrados en el apartado "Comportamiento de los elementos de fricción".

Su valor es por tanto variable, estimándose para el cálculo $k= 1,25$ tanto para los freno-embragues neumáticos como para los hidráulicos.

El tiempo total de frenado será:

$$t_t = t_{11} + t_3$$

t_{11} : también es variable tanto en los neumáticos como en los hidráulicos.

CÁLCULO DEL ÁNGULO DE FRENADO θ_f

El ángulo de frenado θ_f se divide en dos términos:

- 1.- Angulo de reacción: $\theta_r = w \cdot t_{11}$
- 2.- Angulo de frenado mecánico (θ_m):

$$\theta_m = f(M, J, w, t_{12}, t_3)$$

$$\theta_f = \theta_r + \theta_m$$

Para simplificar el cálculo se puede utilizar la siguiente fórmula:

$$\theta_f = w \cdot t_{11} + \frac{w}{2} \cdot t_3 \text{ (rad) ó}$$

$$\theta_f = 6 \cdot n \cdot t_{11} + 3 \cdot n \cdot t_3 \text{ (}^\circ\text{)}$$

n : velocidad angular del freno-embrague (r.p.m.).

Please find below graphics showing comparasion measurements taken by an oscilloscope, of the brake engagement of a hydraulic clutch-brake and a pneumatic clutchbrake respectively:

A continuación se pueden ver los gráficos de ejemplos de mediciones reales realizadas con osciloscopio, del proceso de frenado de un freno-embrague hidráulico y de uno neumático respectivamente:

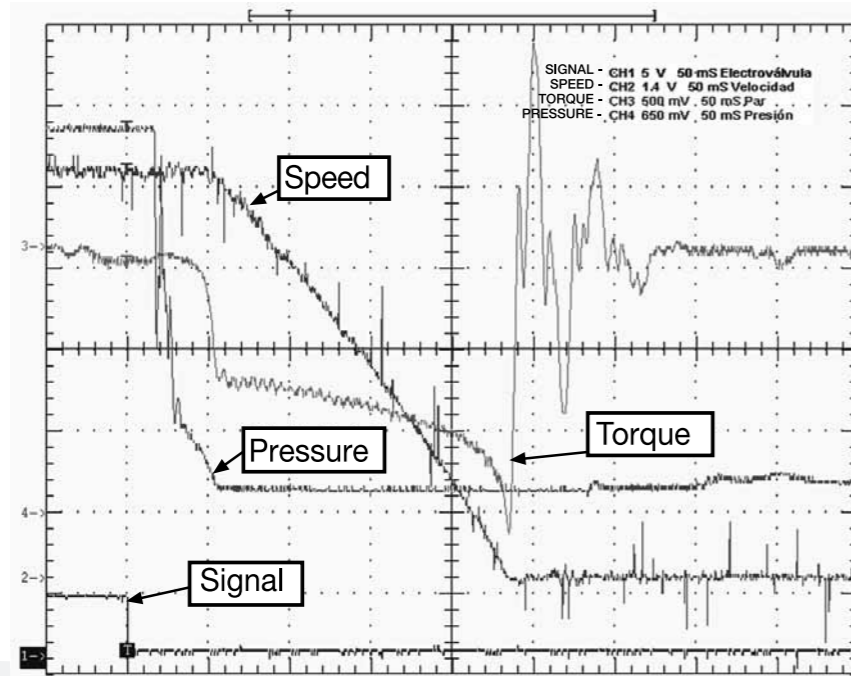

Hydraulic clutch-brake unit
Freno-embrague hidráulico

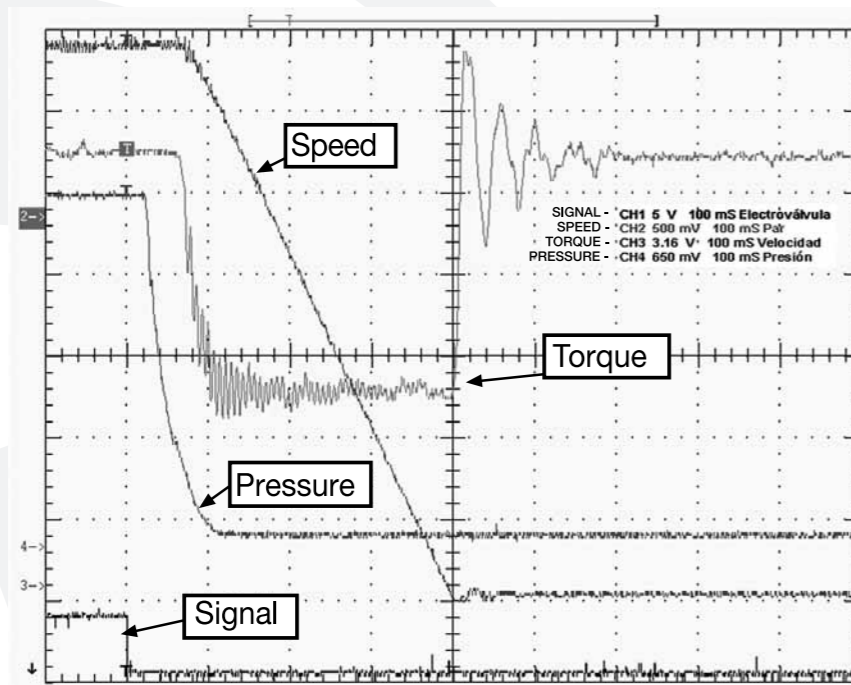

Pneumatic clutch-brake unit
Freno-embrague neumático

TORQUE CALCULATION FOR AN ECCENTRIC PRESS

To calculate the necessary torque in an eccentric press, the following formulation is used:

$$M = \frac{\sin(\alpha + \beta)}{\cos \beta} \cdot P \cdot r$$

- M : turning torque to be transmitted by the eccentrical shaft.
- α : maximum effort angle before the BDC (bottom dead center).
- P : force of the press.
- r : radius of the eccentric.
- β : angle between the connecting rod and the movement line of the ram in the moment of maximum force.
- s : distance from the BDC to the point where the maximum effort is produced (measured at the ram).
- h : distance from the BDC to the point where the maximum force is produced (measured at the eccentric).

To obtain angles " α " and " β ", and "h" height, the following formulations are used:

$$\sin \alpha = \sqrt{1 - \left(\frac{r-h}{r}\right)^2}$$

$$h = \frac{L^2 - (L-s)^2}{2 \cdot (L-s+r)}$$

$$\frac{r}{L} = \frac{\sin \beta}{\sin \alpha}$$

In the case where the "r" and "L" values are not known, an estimated calculation about the transmissible torque can be made by using the following formulation:

$$M = F \cdot r = \frac{\sin(\alpha + \beta)}{\cos \beta} \cdot P \cdot r = K \cdot P \cdot r$$

Taking $\frac{L}{r} = 5$ (estimated), the K value is:

CÁLCULO DEL PAR EN UNA PRENSA EXCÉNTRICA

Para el cálculo del par necesario en una prensa excéntrica, se emplea la siguiente fórmula:

$$M = \frac{\text{sen}(\alpha + \beta)}{\cos \beta} \cdot P \cdot r$$

- M : momento de giro a transmitir por el eje excéntrico.
- α : ángulo de esfuerzo máximo antes del PMI (punto muerto inferior).
- P : esfuerzo de la prensa.
- r : radio de excéntrica.
- β : ángulo formado entre la biela y la línea del movimiento del carro en el momento del esfuerzo máximo.
- s : distancia (medida en el carro) desde el PMI al punto donde se produce el esfuerzo máximo.
- h : distancia (medida en la excéntrica) desde el PMI al punto donde se produce el esfuerzo máximo.

Para la obtención de los ángulos " α " y " β " y la altura "h" se emplean las siguientes fórmulas:

$$\text{sen } \alpha = \sqrt{1 - \left(\frac{r-h}{r}\right)^2}$$

$$h = \frac{L^2 - (L-s)^2}{2 \cdot (L-s+r)}$$

$$\frac{r}{L} = \frac{\text{sen } \beta}{\text{sen } \alpha}$$

En el caso de que no se conozcan los valores arriba indicados "r" y "L" se puede realizar un cálculo orientativo del par transmisible utilizando la siguiente fórmula:

$$M = F \cdot r = \frac{\text{sen}(\alpha + \beta)}{\cos \beta} \cdot P \cdot r = K \cdot P \cdot r$$

Tomando $\frac{L}{r} = 5$ (orientativo), el valor de K es:

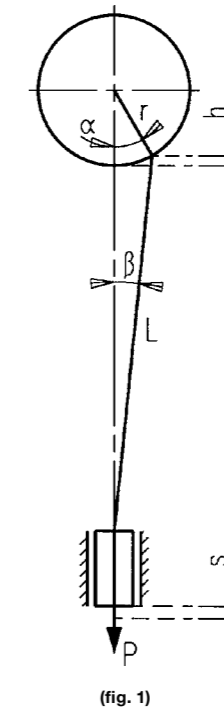

(fig. 1)

CLUTCH-BRAKES SERIES 5.8

FRENO-EMBRAGUES SERIE 5.8

For $\alpha = 30^\circ$ the coefficient $K = 0,587$
 For $\alpha = 15^\circ$ the coefficient $K = 0,3$
 For $\alpha = 40^\circ$ the coefficient $K = 0,74$
 For shears $K = 1$
 When the clutch is in a faster shaft:

$$M_{red} = \frac{M}{i}$$

"i" Being the transmission ratio between the clutch shaft and the eccentric shaft.

Para $\alpha = 30^\circ$ el coeficiente $K = 0,587$
 Para $\alpha = 15^\circ$ el coeficiente $K = 0,3$
 Para $\alpha = 40^\circ$ el coeficiente $K = 0,74$
 Para cizallas $K = 1$
 Cuando el embrague está en un eje más rápido:

$$M_{red} = \frac{M}{i}$$

Siendo "i" la relación de transmisión entre el eje del embrague y el eje excéntrico.

PNEUMATIC SCHEME

A standard pneumatic scheme of the assembly of a clutch-brake would be:

- 1) Filter
- 2) Pressure regulator
- 3) Lubricator
- 4) Air accumulator
- 5) Electrovalve
- 6) Rotary union
- 7) Clutch-brake

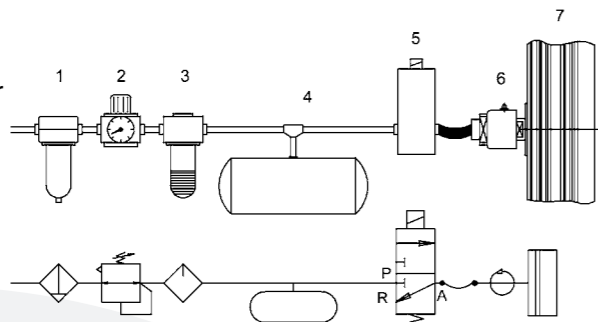

- 1) Filtro
- 2) Regulador de presión
- 3) Lubricador
- 4) Acumulador de aire
- 5) Electroválvula
- 6) Rácor giratorio
- 7) Freno-embrague

ESQUEMA NEUMÁTICO

Un esquema neumático estándar para el montaje de un freno-embrague sería el siguiente:

The quantity of air to be supplied by the compressor should be calculated with the following formulation:

$$Q = 1,5 \cdot V \cdot p \cdot F \text{ (l/min)}$$

- Q : necessary air quantity.
 V : volume of the clutch cylinder plus the volume of the pipe between the clutch and the valve indicated in the catalogue.
 p : maximum service pressure (bar).
 F : cycles per minute.
 1,5 : coefficient (compensation lost by leak).

The volume of the recommended vessel comes from the following formulation:

$$V_{DC} = 4 \cdot p \cdot V$$

V_{DC} : accumulator volume (litres)

La cantidad de aire a ser suministrada por el compresor se calcula con la siguiente fórmula:

$$Q = 1,5 \cdot V \cdot p \cdot F \text{ (l/min)}$$

- Q : cantidad de aire necesaria
 V : volumen del cilindro del freno-embrague en el caso de desgaste máximo (aparece en el catálogo), más el volumen de la tubería que hay entre el freno-embrague y la válvula.
 p : presión máxima de servicio (bar).
 F : frecuencia de maniobras por minuto.
 1,5 : coeficiente (compensación pérdida por fuga).

El volumen del depósito recomendado (VDC) viene dado por la siguiente fórmula:

$$V_{DC} = 4 \cdot p \cdot V$$

V_{DC} : volumen del acumulador (litros)

This series corresponds to the latest of the pneumatic clutch-brakes developed by GOIZPER.

One of its main characteristics is that it obtains the maximum possible torque within the dimensions of the unit, due to the fact that the piston reaches the maximum diameter.

These clutch-brakes may be mounted with locking rings or keyways.

Esta serie corresponde al último de los frenoembragues neumáticos desarrollados por GOIZPER.

Entre sus características principales, destaca que se consigue el máximo par posible dentro de las medidas de la unidad, gracias a que el pistón alcanza el diámetro máximo.

Estos freno-embragues están preparados para ser montados con anillos de fijación o con chavetas.

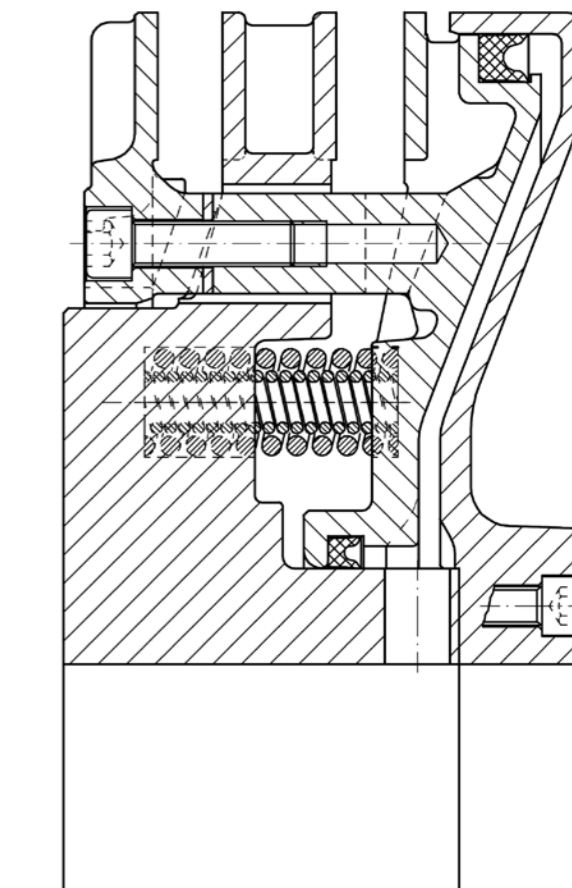

Series 5.81.*.WD

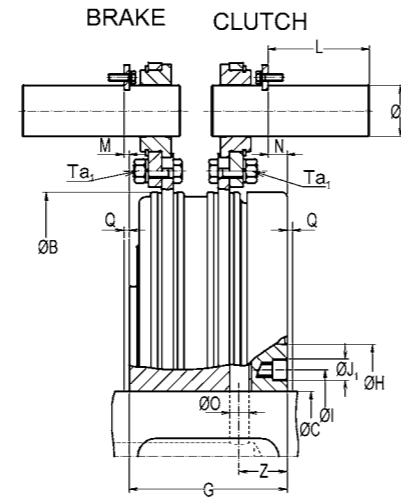
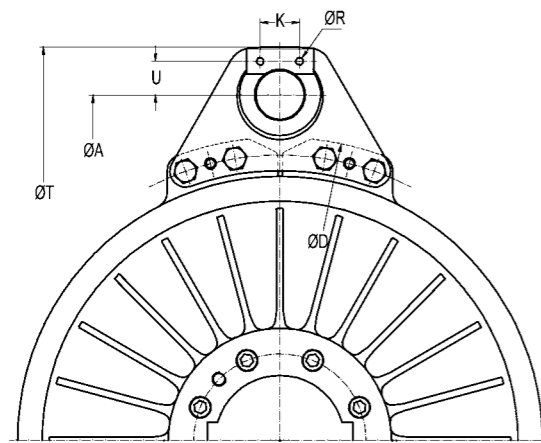

Series 5.82.*.WD

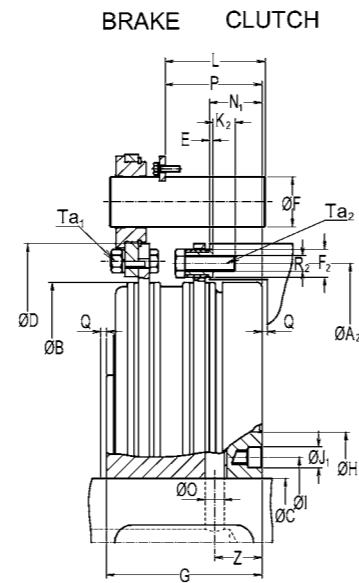
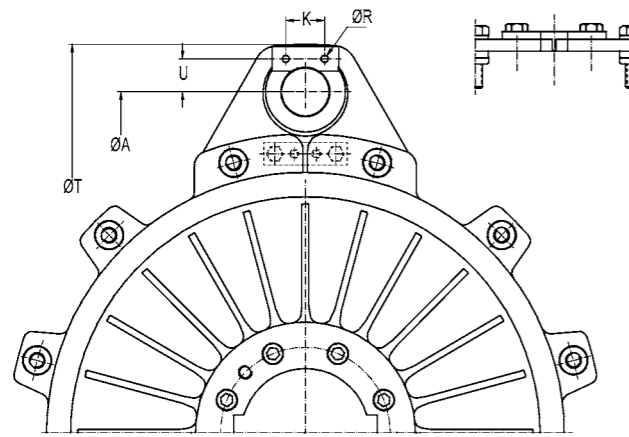

Series 5.84.*.WD

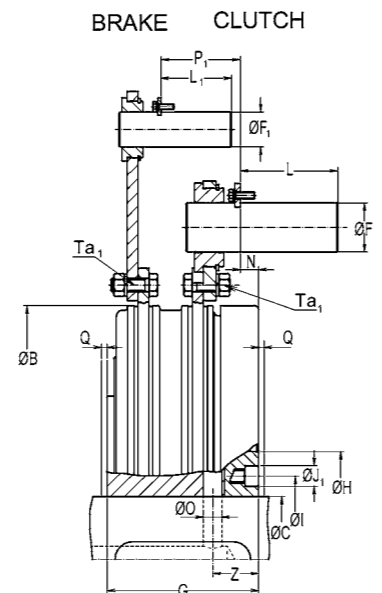
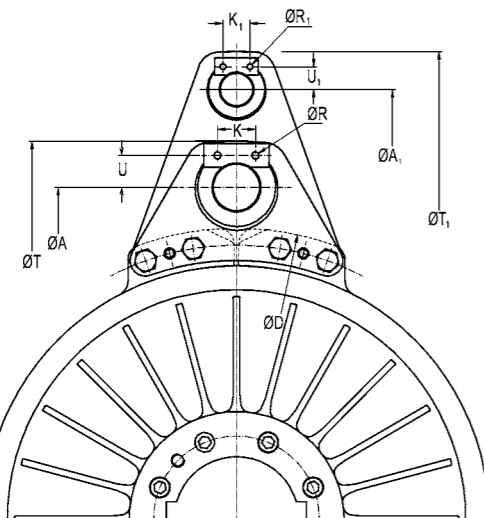

SERIES		5.81.__.WD / 5.82.__.WD / 5.84.__.WD											
SIZE		23	50	10	18	36	55	75	76	77	78	80	
Clutch torque	Nm	480	940	2000	4000	7550	11900	15500	22900	32000	42800	56600	
Brake torque		345	665	1450	2850	5390	8500	11200	16300	22850	30500	38500	
Pressure	bar	5,5											
Max speed	min ⁻¹	2750	2250	1750	1500	1250	1100	1000	850	750	700	630	
Weight	Kg	581 WD	9.2	15.5	32	60	112	170	228	325	453	655	820
		582 WD	9	15	30	58	106	163	220	313	437	615	774
		584 WD	9.2	15.5	32	60	112	170	228	325	453	655	820
J. int.	Kg m ²	0.026	0.07	0.25	0.72	1.85	4.24	6.6	12.2	21.1	31.5	51.4	
J. ext.	Kg m ²	581 WD	0.013	0.04	0.1	0.283	0.953	1.546	2.91	4.97	8.82	20	27.3
		582 WD	0.008	0.027	0.062	0.202	0.615	1.031	1.55	3.34	6.51	10.5	12.8
		584 WD	0.013	0.04	0.1	0.283	0.953	1.546	2.91	4.97	8.82	20	27.3
New vol	dm ³	0.093	0.164	0.320	0.671	1.18	1.75	2.23	3.21	4.88	6.42	8.38	
Max. wear Volum.		0.148	0.250	0.524	1.038	1.95	2.79	3.58	5.23	7.62	9.97	13.6	
Ø A		250	315	390	495	610	695	770	880	970	1100	1180	
Ø A1		325	410	490	635	790	885	990	1135	1235	1450	1525	
Ø A2		205	255	325	408	500	584	640	725	810	890	965	
Ø B		188	236	305	380	466	543	593	675	755	830	905	
Ø C	Min.	28	35	45	55	70	80	90	100	115	115	135	
(H7)	Max.	48	65	80	95	125	145	160	180	200	220	240	
Ø D		226	275	347	435	535	620	680	775	865	950	1025	
E		1.7	2	3	3	3	3	3	4	4	4	4	
Ø F		15	22	30	32	45	45	60	60	65	75	80	
Ø F ₁	12 x 30°	15	15	22	30	32	32	45	45	60	65	65	
Ø F ₂		10	12	15	18	25	25	30	35	40	45	45	
G		66	75	92	112	140	160	175	195	220	240	260	
Ø H		85	105	141	168	198	224	250	294	324	354	390	
Ø I		60	79	99	118	153	176	194	221	246	270	305	
Ø J ₁		9.5	11	13.5	16.5	19	19	23	25	28	33	33	
K ₁		20	25	25	25	35	35	45	45	45	60	60	
K ₂		20	20	25	25	25	25	35	35	45	45	45	
K ₃		7.5	11	13	16	20	20	25	38	43	36	36	
L		30	45	60	65	90	90	120	120	130	150	160	
L ₁		30	30	45	60	65	65	90	90	120	130	130	
M		3	4	4	5	5	5	5	5	5	20	15	
N		7.5	8	10.5	13	17	22	24	26	28	17	28	
N ₁		22	25.5	31.5	38	47	55	61	66	75	81	90	
Ø O ₁	2 x 180°	6	8	10	14	17	20	22	25	28	30	35	
P		38	40	54	69	87	102	110	125	136	141.5	157	
P ₁		32	38.5	45	58	73	84	86	100	114	121.5	132	
Q _(r)		3	4	4	5	5	5	5	5	5	5	5	
Ø R		4.5	5.5	5.5	5.5	6.5	6.5	8.5	8.5	8.5	10.5	10.5	
Ø R ₁	12 x 30°	4.5	4.5	5.5	5.5	5.5	5.5	6.5	6.5	8.5	8.5	8.5	
Ø R ₂		M5	M6	M8	M10	M14	M14	M16	M20	M24	M24	M24	
Ø T		284	360	446	565	695	785	880	1000	1110	1260	13340	
Ø T ₁		359	444	535	691	860	955	1075	1220	1345	1595	1670	
Ø U		11	16	20	21	29.5	29.5	41	41	43.5	52.5	55	
Ø U ₁		11	11	16	20	21	21	29.5	29.5	41	43.5	43.5	
Z		17	22	28	36	42.5	51	55	62.5	71	78	86	
Ta ₁	Nm	6,6	11	27,5	54	95	148	230	230	450	780	780	
Ta ₂		6	10	25	49	135	135	210	410	710	710	710	

(*) Space to indicate the size
 (*) Espacio para indicar el tamaño

(*) Space required for instalation
 (*) Espacio libre requerido

Series 5.85.*.WD

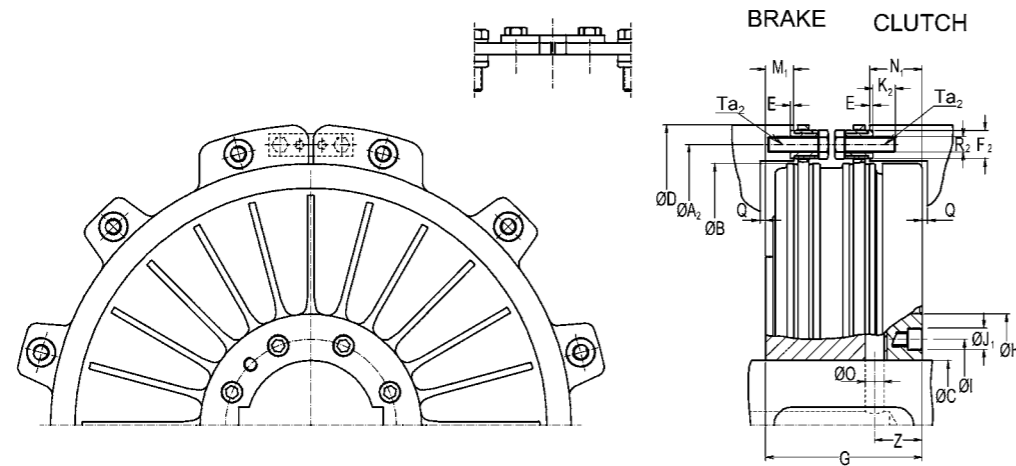

Series 5.85.*.WA

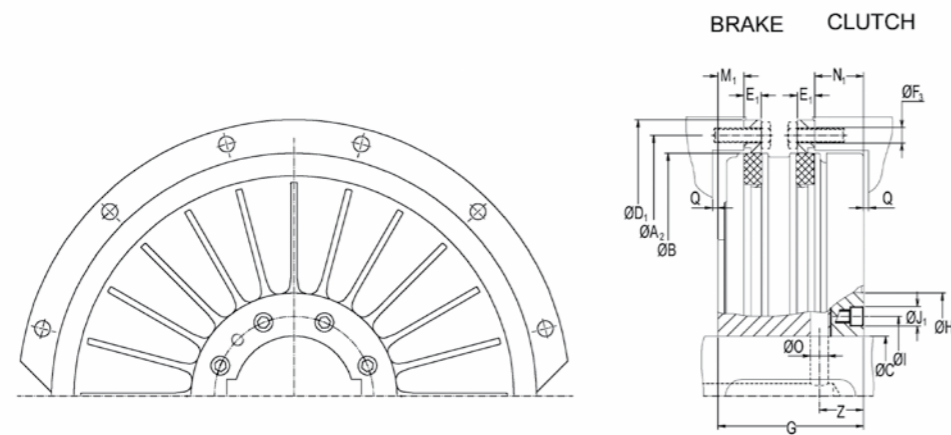

Series 5.86.*.WD

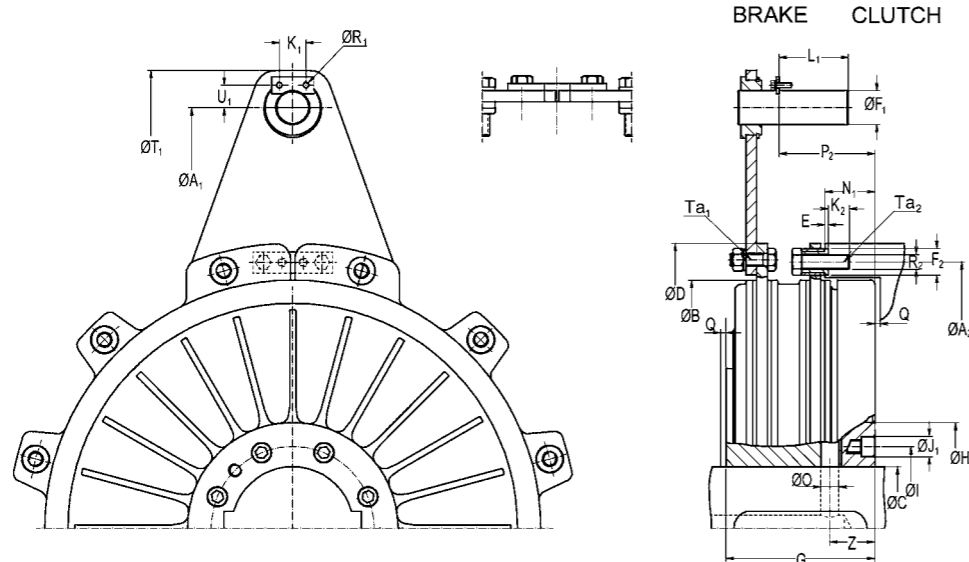

(*) Space to indicate the size
(*) Espacio para indicar el tamaño

SERIES		5.85.*.WD / 5.85.*.WA / 5.86.*.WD										
SIZE		23	50	10	18	36	55	75	76	77	78	80
Clutch torque	Nm	480	940	2000	4000	7550	11900	15500	22900	32000	42800	56600
Brake torque		345	665	1450	2850	5390	8500	11200	16300	22850	30500	38500
Pressure	bar	5,5										
Max speed	min ⁻¹	2750	2250	1750	1500	1250	1100	1000	850	750	700	630
Weight	585 WD	9	14	29	60	100	157	210	300	421	575	728
	585 WA	8.5	15	30	56	103	161	211	306	424	555	723
	586 WD	9.2	15	30	58	105	162	218	311	438	615	775
J. int.	Kg m ²	0.026	0.07	0.25	0.72	1.85	4.24	6.6	12.2	21.1	31.5	51.4
J. ext.	585 WD	0.008	0.027	0.062	0.202	0.615	1.031	1.55	3.34	6.51	10.5	12.8
	585 WA	0.008	0.020	0.057	0.170	0.535	1.047	1.50	3	5.33	9.2	12.6
	586 WD	0.008	0.027	0.062	0.202	0.615	1.031	1.55	3.34	6.51	10.5	12.8
New vol	dm ³	0.093	0.164	0.320	0.671	1.18	1.75	2.23	3.21	4.88	6.42	8.38
Max. wear Volum.		0.148	0.250	0.524	1.038	1.95	2.79	3.58	5.23	7.62	9.97	13.6
Ø A1		325	410	490	635	790	885	990	1135	1235	1450	1525
Ø A2		205	255	325	408	500	584	640	725	810	890	965
Ø B		188	236	305	380	466	543	593	675	755	830	905
Ø C (H7)	Min.	28	35	45	55	70	80	90	100	115	115	135
	Max.	48	65	80	95	125	145	160	180	200	220	240
Ø D		226	275	347	435	535	620	680	775	865	950	1025
Ø D ₁		220	275	345	430	530	620	680	770	860	945	1020
E		1.7	2	3	3	3	3	3	4	4	4	4
E ₁		8.5	9.5	11.5	13.5	18.5	19	18.5	23	27.5	31	32.5
Ø F ₁		15	15	22	30	32	32	45	45	60	65	65
Ø F ₂		10	12	15	18	25	25	30	35	40	45	45
Ø F ₃	12 x 30°	5.5	7	8.5	10.5	15	15	17	21	25	25	25
G		66	75	92	112	140	160	175	195	220	240	260
Ø H		85	105	141	168	198	224	250	294	324	354	390
Ø I		60	79	99	118	153	176	194	221	246	270	305
Ø J ₁		9.5	11	13.5	16.5	19	19	23	25	28	33	33
K ₁		20	20	25	25	25	25	35	35	45	45	45
K ₂		7.5	11	13	16	20	20	25	38	43	36	36
L ₁		30	30	45	60	65	65	90	90	120	130	130
M ₁		11	13.5	17	20	25	28	32	35	40	44	48
N ₁		22	25.5	31.5	38	47	55	61	66	75	81	90
Ø O ₁	2 x 180°	6	8	10	14	17	20	22	25	28	30	35
		39.5	46.5	55.5	71	90	106	110	126	142	138.5	160
Q _(*)		3	4	4	5	5	5	5	5	5	5	5
Ø R ₁		4.5	4.5	5.5	5.5	5.5	5.5	6.5	6.5	8.5	8.5	8.5
	12 x 30°	M5	M6	M8	M10	M14	M14	M16	M20	M24	M24	M24
Ø T ₁		359	444	535	691	860	955	1075	1220	1345	1595	1670
Ø U ₁		11	11	16	20	21	21	29.5	29.5	41	43.5	43.5
Z		17	22	28	36	42.5	51	55	62.5	71	78	86
Ta ₁	Nm	6,6	11	27,5	54	95	149	230	230	450	780	780
Ta ₂		6	10	25	49	135	135	210	410	710	710	710

(*) Space required for installation
(*) Espacio libre requerido

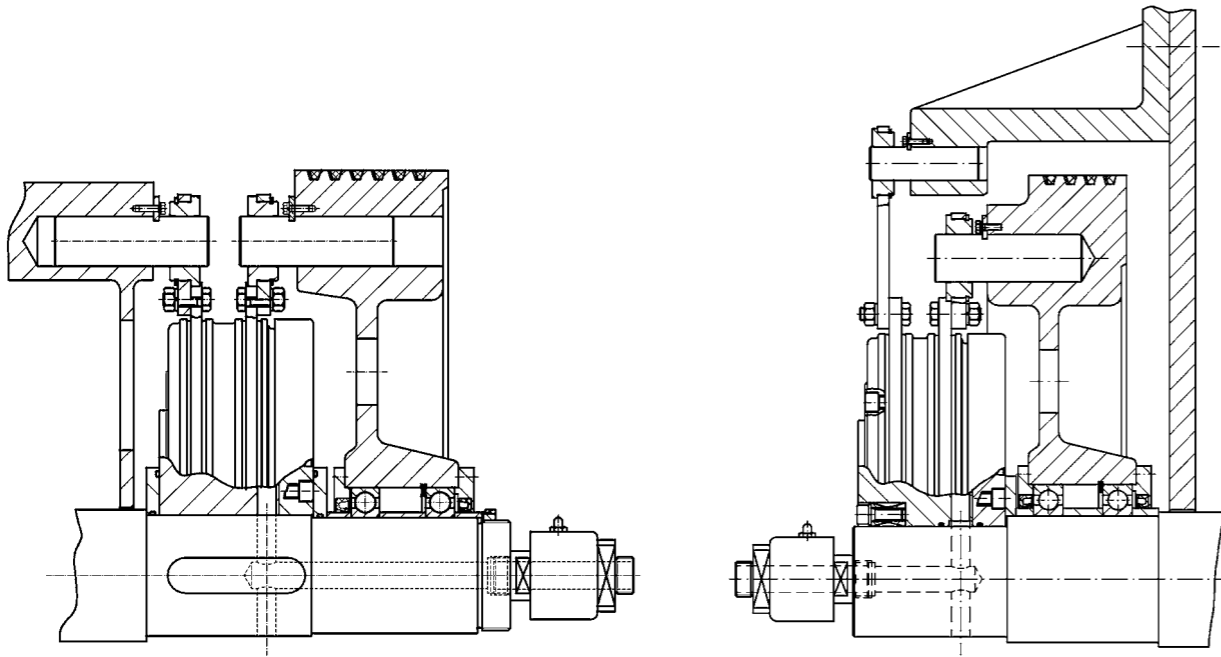

Series 5.81. __. WD

Mounting between frame and flywheel by means of identical pins on the clutch side as well as on the brake side.

Montaje entre bastidor y volante con bulones iguales en el lado embrague y lado freno.

Series 5.84. __. WD

Mounting at shaft end by means of pins on different diameters on both clutch and brake side. Fixed in the shaft by locking ring.

Montaje en el extremo del eje con bulones en el lado embrague y en el lado freno situados en diámetros distintos. Montado en el eje con anillo fijación.

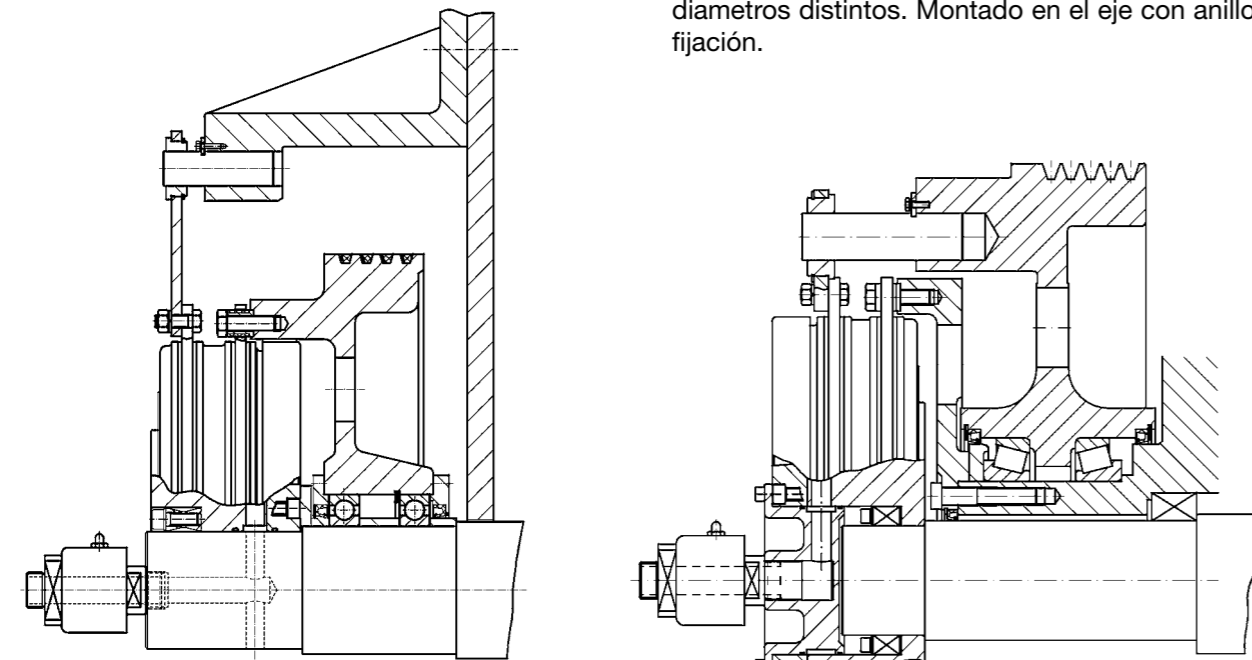

Series 5.86. __. WE

Mounting at shaft end by means of pads in clutch side and pins in brake side. Fixed on the shaft by locking ring.

Montaje en el extremo del eje con tacos en el lado embrague y bulones en el lado freno. Montado en el eje con anillo de fijación.

Series 5.83. __. CD

Mounting at shaft end by means of 12 bushings on the brake side and 2 pins on the clutch side. Fixed on the shaft by locking ring. Special air feeding via air inlet block.

Montaje en el extremo del eje con 12 casquillos en el lado freno y 2 bulones en el lado embrague. Montado en el eje con anillo de fijación. Alimentación de aire especial.

Torque Ratings 5.8 / Rango de Pares 5.8

SIZE	QUANTITY OF SPRINGS	BRAKE TORQUE (N.m)	CLUTCH TORQUE (N.m)	
			5,5 bar	6 bar
23	18	410	410	485
	15	345	480	560
	12	275	555	630
	9	205	625	705
	6	135	700	775
50	18 + 18	800	800	950
	15 + 15	665	940	1090
	12 + 12	535	1080	1230
	9 + 9	400	1220	1370
10	6 + 6	270	1360	1510
	18 + 18	1750	1700	2050
	15 + 15	1450	2000	2350
	12 + 12	1150	2350	2650
	9 + 9	880	2650	2950
18	6 + 6	580	2950	3290
	18 + 18	3400	3450	4050
	15 + 15	2850	4000	4650
	12 + 12	2250	4600	5250
36	9 + 9	1700	5200	5850
	6 + 6	1150	5800	6450
	18 + 18	6450	6400	7600
	15 + 15	5390	7550	8700
	12 + 12	4300	8650	9840
55	9 + 9	3200	9750	10900
	6 + 6	2150	10800	12000
	21 + 21	9950	10450	12400
	18 + 18	8500	11900	13800
75	15 + 15	7100	13400	15300
	12 + 12	5700	14900	16800
	9 + 9	4250	16400	18300
	21 + 21	13000	13600	16100
	18 + 18	11200	15500	18000
76	15 + 15	9300	17500	20000
	12 + 12	7400	19400	21900
	9 + 9	5600	21400	23800
	21 + 21	19000	20000	23700
77	18 + 18	16300	22900	26500
	15 + 15	13600	25700	29300
	12 + 12	10900	28500	32200
	9 + 9	8150	31400	35000
	21 + 21	26700	28000	33100
78	18 + 18	22850	32000	37100
	15 + 15	19000	36000	41100
	12 + 12	15200	40000	45100
	9 + 9	11400	44000	49100
80	21 + 21	35600	37500	44300
	18 + 18	30500	42800	49600
	15 + 15	25400	48100	54900
	12 + 12	20300	53400	60200
	9 + 9	15200	58700	65500
80	24 + 24	44000	50800	59700
	21 + 21	38500	56600	65500
	18 + 18	33000	62500	71300
	15 + 15	27500	68300	77100

CLUTCH-BRAKES SERIES 5.7

FRENO-EMBRAGUES SERIE 5.7

This is the latest series of traditional clutchbrakes designed by Goizper with maximum piston size for each clutch-brake.

Sizes 10, 18 and 36 are interchangeable with the corresponding sizes in series 5.0.

Sizes 55, 75, 76, 77 and 78 have the same diameters as their corresponding size from series 5.0 but are wider. They have very high torques and can be mounted with locking rings from both clutch and brake sides. Spacers are provided to allow lining wear compensation.

Esta serie consigue dentro del diseño tradicional de freno-embrague de GOIZPER, el máximo par para cada uno de los diferentes tamaños.

Los tamaños 10, 18 y 36 son intercambiables con los mismos tamaños de la serie 5.0.

Los tamaños 55, 75, 76, 77 y 78 tienen los mismos diámetros que los correspondientes de la serie 5.0 pero son más anchos, además ofrecen unos pares muy elevados. Pueden ir montados con anillos de fijación tanto por el lado del embrague como por el del freno, y tienen la posibilidad de compensar el desgaste de las guarniciones.

SERIES 5.7

Sizes / Tamaños : 05 / 11 / 16 / 23 / 50 / 10 / 13 / 18 / 36

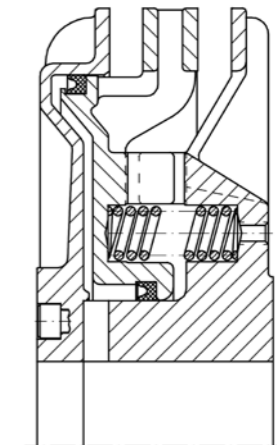

SERIES 5.7

Sizes / Tamaños : 19N / 25N / 37N / 55 / 75 / 76 / 77 / 78 / 80 / 81 / 82

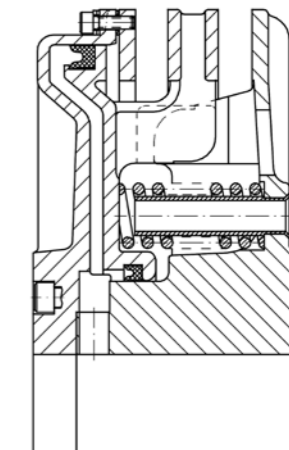

Series 5.71.*.WD

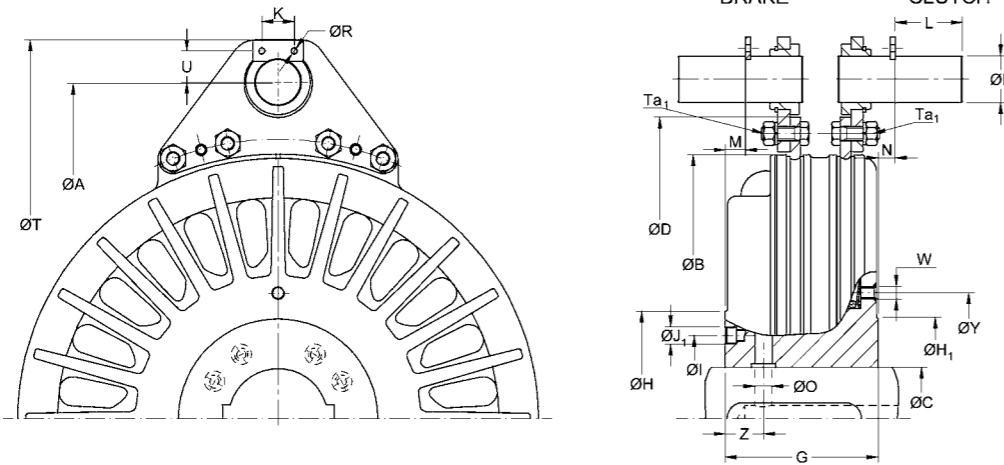

Series 5.72.*.WD

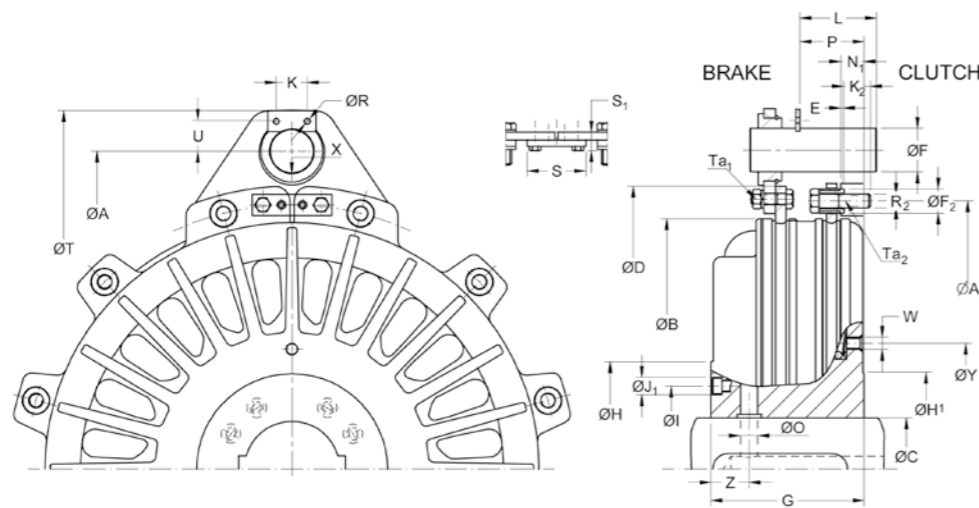

Series 5.74.*.WD

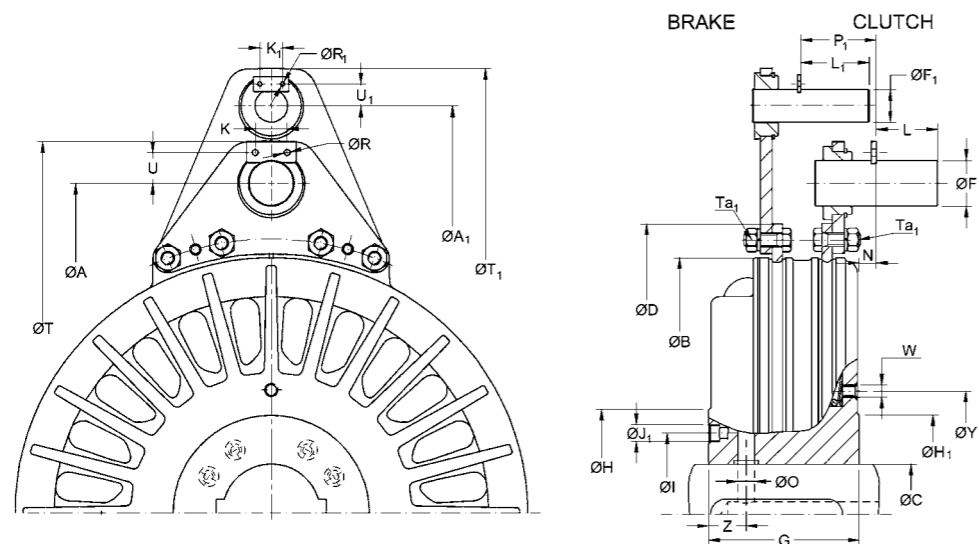

(*) Space to indicate the size
(*) Espacio para indicar el tamaño

SERIES		5.71.__.WD / 5.72.__.WD / 5.74.__.WD																			
SIZE		05	11	16	23	50	10	13	18	19N	25N	36	37N	55	75	76	77	78	80	81	82
Clutch torque	Nm	65	175	205	265	695	1465	1465	2760	3430	4785	5710	6720	9500	13400	19100	29300	39000	50000	70000	98000
Brake torque		28	75	125	185	490	1030	1030	1960	2495	3410	4060	4780	8000	10000	15800	20500	27600	36000	50000	71500
Pressure	bar	5,5																			
Max speed	min ⁻¹	3500	3200	3200	2700	2250	1750	1750	1450	1450	1300	1200	1200	1000	900	800	750	700	630	560	500
Weight	571 WD	3,5	7	6,5	9	17	26	27	47	57	74	86	107	149	197	273	443	655	765	953	1360
	572 WA	3	6,5	6	8,5	16	25	26	45	55	73	85	106	143	185	264	432	615	723	916	1280
	574 WD	3,5	7	6,5	9	17	26	27	47	57	74	86	107	149	197	273	443	655	768	963	1346
J. int.	Kg m ²	0,004	0,013	0,014	0,022	0,05	0,173	0,173	0,5	0,65	1,06	1,41	1,72	3,81	5,58	10,5	19,27	30,65	45,55	80,6	139
J. ext.	571 WD	0,003	0,005	0,009	0,032	0,043	0,114	0,114	0,274	0,274	0,56	0,768	0,847	1,35	2,14	4,57	7,51	20	26,6	33,6	29,2
	572 WA	0,002	0,003	0,005	0,008	0,027	0,062	0,062	0,202	0,202	0,382	0,53	0,609	1,04	1,55	3,34	6,51	10,7	13,1	20	17,3
	574 WD	0,003	0,005	0,009	0,032	0,043	0,114	0,114	0,274	0,274	0,56	0,768	0,847	1,35	2,14	4,57	7,51	20	26,6	33,5	29,2
New vol	dm ³	0,02	0,035	0,04	0,072	0,145	0,276	0,276	0,43	0,58	0,78	0,74	0,98	1,45	1,76	2,84	4,45	5,2	6,9	9,3	12,5
Max. wear Volum.		0,045	0,075	0,06	0,12	0,273	0,462	0,462	0,74	0,98	1,36	1,26	1,76	2,5	3,12	5,2	8,26	10,2	11,7	16,4	21,9
Ø A		180	220	230	250	315	390	390	495	495	550	610	610	695	770	880	970	1100	1180	1300	1465
Ø A ₁		-	-	305	325	410	490	490	635	635	710	790	790	885	990	1135	1235	1450	1525	1645	1855
Ø A ₂		135	173	182	205	255	325	325	408	408	450	500	500	584	640	725	810	890	965	1080	1215
Ø B		120	158	166	188	236	305	305	380	380	420	466	466	543	593	675	755	830	905	1015	1140
Ø C	Min.	14	19	19	25	30	35	35	45	45	45	50	50	64	90	100	125	125	140	150	170
	Max.	24	35	35	35	52	65	65	90	90	95	110	110	150	165	180	180	200	220	240	300
Ø D		151	192	198	226	275	347	347	435	435	482	535	535	620	690	775	865	950	1025	1145	1276
E		2	2	2	2	2	3	3	3	3	3	3	3	5	5	5	10	10	10	10	10
Ø F		12	12	14	14	22	22	22	30	30	32	40	40	40	45	55	55	75	75	75	90
Ø F ₁	12 x 30°	-	-	14	14	14	14	14	22	22	30	30	30	40	45	45	65	65	65	75	90
Ø F ₂		9 (6)	10 (6)	10	10	12	15	15	18	18	22	25	25	25	30	35	40	45	45	50	55
G		42	50	46	58	66	82	82	100	112	125	125	140	160	185	205	230	248	260	295	330
Ø H		60	65	75	70	97	125	125	153	172	192	190	210	245	270	310	320	345	395	450	490
Ø H ₁		60	65	121	70	90	130	130	145	160	166	180	190	250	270	290	320	350	370	450	490
Ø I		35	47	51	47	65	81,5	81,5	109	129	142	133	156	192	214	240	256	285	319	366	417
Ø J ₁		9	9,5	9	9,5	10,5	13,5	13,5	13,5	13,5	17	19	16,5	20	20	26	26	26	26	30	42
K ₁		16	16	20	20	25	25	25	25	25	25	35	35	35	35	45	45	60	60	60	60
K ₂		-	-	20	20	20	20	20	25	25	25	25	25	25	35	35	35	45	45	45	60
K ₃		8	8	8	8	12	13	14	16	16	20	20	23	24	28	38	43	45	45	46	55
L		18	22	25	28	45	45	45	60	60	65	80	80	80	90	110	110	150	150	150	180
L ₁		-	-	25	28	28	28	28	45	45	60	60	60	60	80	90	90	130	130	130	150
M		2	1	0,5	0	0	1	2,5	3	19	25	4	22,5	25	39,5	38	48,5	34,5	38,5	57,5	59,5
N		6	8	5,5	10	8,5	12,5	10	15	12	7	15	10,5	13	12,5	18	12,5	26,5	22,5	16,5	19,5
N ₁		5	6	8	9	11	14	14	14,5	16	18	17	22	25	27	29	34	38	42	46	52
Ø O ₁	2 x 180°	4	5	4	6	6	10	10	12	13,5	14	14	16	18	20	21	23	25	32	32	35
P		6	13	18	18	24	27	27	39	39	48	58	58	63	65	80	95	99	99,5	120,5	142,5
P ₁		-	-	26,5	27	39	46,5	49	53	52	54	74	66,5	80,5	81	98,5	107,5	120,5	124,5	134,5	158
Ø R	12 x 30°	4,5	4,5	4,5	4,5	5,5	5,5	5,5	5,5	5,5	5,5	6,5	6,5	6,5	6,5	8,5	8,5	10,5	10,5	10,5	10,5
Ø R ₁		-	-	4,5	4,5	4,5	4,5	4,5	5,5	5,5	5,5	5,5	5,5	5,5	6,5	6,5	6,5	8,5	8,5	8,5	10,5
Ø R ₂		M4(6)	M5(6)	M5	M5	M6	M8	M8	M10	M10	M12	M14	M14	M14	M16	M20	M24	M24	M24	M27	M30
S		30	38	38	38	46	56	56	70	70	75	75	75	84	96	110	120	138	138	138	138
S ₁		6	5,8	5,8	5,8	6,5	9,5	9,5	10,5	10,5	13,5	13,5	13,5	17	17	20	21	24	24	24	24
Ø T		203	242	262	280	360	435	435	560	560	622	695	695	780	870	1000	1090	1260	1340	1460	1650
Ø T ₁		-	-	337	361	446	527	527	680	680	775	855	855	950	1075	1220	1335	1595	1670	1790	2015
Ø U		10,5	10,5	11	11	16	16	16	20	20	21	27	27	27	29,5	38,5	38,5	52,5	52,5	52,5	60
Ø U ₁		-	-	11	11	11	11	11	16	16	20	20	20	20	27	29,5	29,5	43,5	43,5	43,5	52,5
W		M5	M5	M6	M6	M6	M8	M8	M8	M8	M10	M12	M12	M16	M16	M16	M16	M18	M18	M20	M24
Ø Y		35	47	67	47	113	146	146	182	205	240	226,5	268	290	329	373	420	470	555	627	696
Z		12	16	15	17	18,5	21	23	26	27	30	31	33	37,5	44	47	55	60	68	76	85
Ta ₁	Nm	6,6	6,6	6,6	6,6	11	27,5	27,5	54	54	54	95	95	148	230	230	450	780	780	780	1500
Ta ₂		2,9	6	6	6	10	25	25	49	49	86	135	135	135	210	410	710	710	710	1050	1450

Series 5.75.*.WD

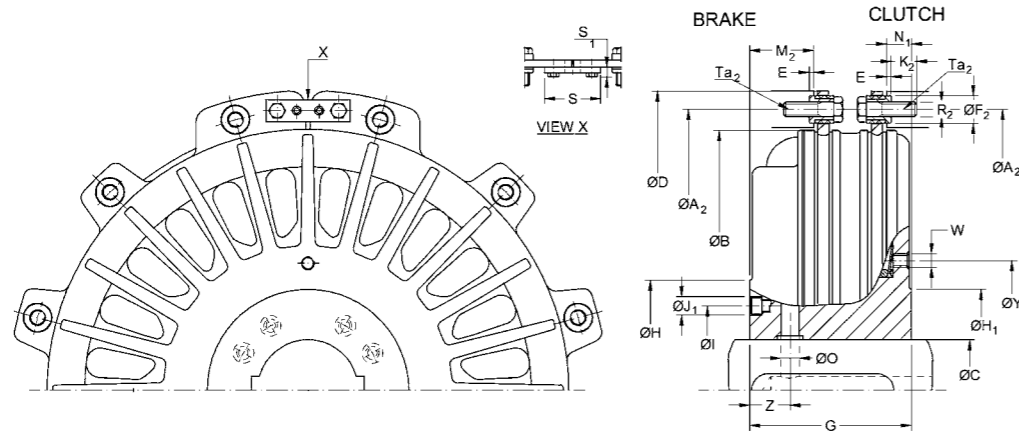

Series 5.75.*.WA

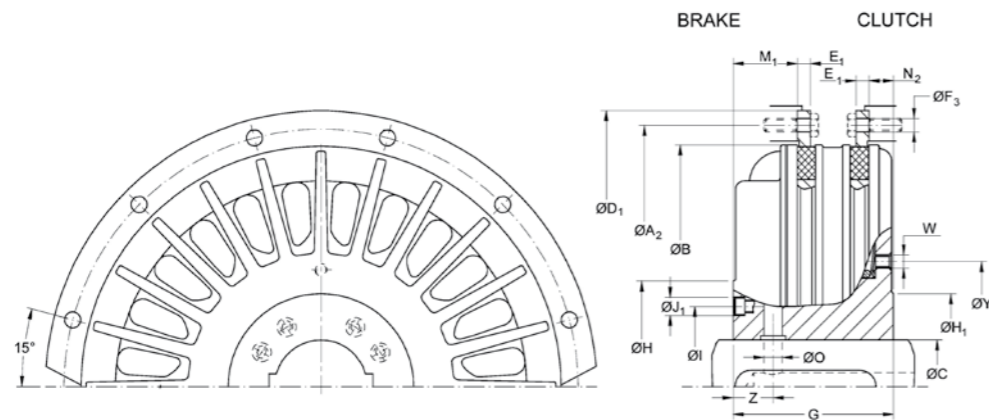

Series 5.76.*.WD

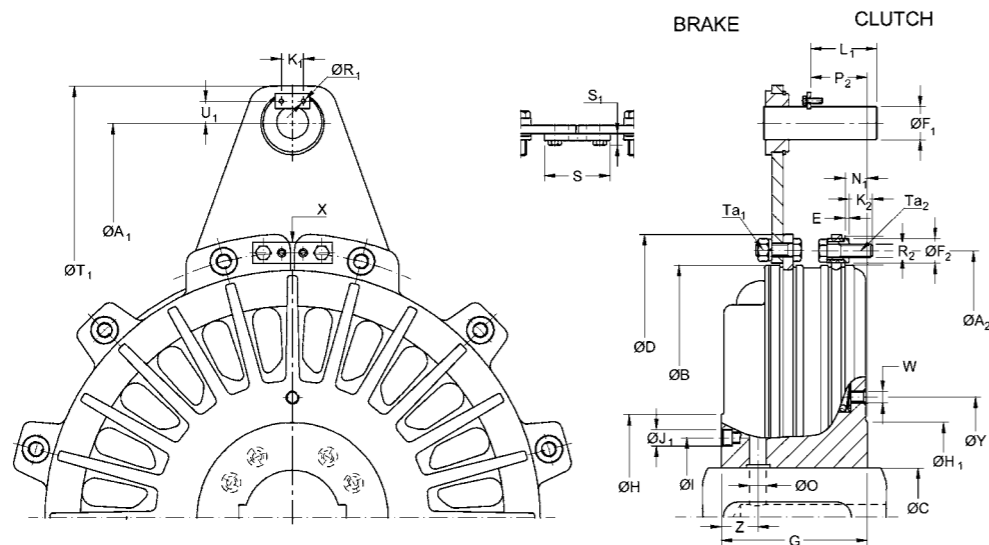

SERIES		5.75.*.WD / 5.75.*.WA / 5.76.*.WD																			
SIZE		05	11	16	23	50	10	13	18	19N	25N	36	37N	55	75	76	77	78	80	81	82
Clutch torque	Nm	65	175	205	265	695	1465	1465	2760	3430	4785	5710	6720	9500	13400	19100	29300	39000	50000	70000	98000
		28	75	125	185	490	1030	1030	1960	2495	3410	4060	4780	8000	10000	15800	20500	27600	36000	50000	71500
Pressure	bar	5,5																			
Max speed	min ⁻¹	3500	3200	3200	2700	2250	1750	1750	1450	1450	1300	1200	1200	1000	900	800	750	700	630	560	500
Weight	575 WD	5,5	6,5	6	8	15	24	25	43	53	70	80	100	138	185	255	421	575	681	879	1215
	575 WA	-	-	-	-	15	24	25	45	55	72	82	102	139	191	265	406	570	653	846	1170
	576 WD	5,5	6,5	6	8,5	16	25	26	45	55	73	84	104	144	195	262	418	615	727	926	1280
J. int.	Kg m ²	0,006	0,013	0,014	0,022	0,05	0,173	0,173	0,5	0,65	1,06	1,41	1,72	3,81	5,58	10,5	19,27	30,65	45,55	80,6	139
J. ext.	575 WD	0,002	0,003	0,005	0,008	0,027	0,062	0,062	0,202	0,202	0,382	0,53	0,609	1,04	1,55	3,34	6,51	10,7	13,1	20	33
	575 WA	-	-	-	-	0,027	0,045	0,045	0,131	0,131	0,26	0,341	0,535	0,881	1,26	2,24	3,87	9,5	10,2	17,7	29,2
	576 WD	0,002	0,003	0,005	0,008	0,027	0,062	0,062	0,202	0,202	0,382	0,53	0,609	1,04	1,55	3,34	6,51	10,7	13,1	20	33
New vol	dm ³	0,02	0,035	0,04	0,072	0,145	0,276	0,276	0,43	0,58	0,78	0,74	0,98	1,45	1,76	2,84	4,45	5,2	6,9	9,3	12,5
Max. wear Volum.		0,045	0,075	0,06	0,12	0,273	0,462	0,462	0,74	0,98	1,36	1,26	1,76	2,5	3,12	5,2	8,26	10,2	11,7	16,4	21,9
Ø A ₁		-	-	305	325	410	490	490	635	635	710	790	790	885	990	1135	1235	1450	1525	1645	1855
Ø A ₂		135	173	182	205	255	325	325	408	408	450	500	500	584	640	725	810	890	965	1080	1215
Ø B		120	158	166	188	236	305	305	380	380	420	466	466	543	593	675	755	830	905	1015	1140
Ø C	Min.	14	19	19	25	30	35	35	45	45	50	50	64	90	100	125	125	140	150	170	
	Max.	24	35	35	35	52	65	65	90	90	95	110	110	150	165	180	180	200	220	240	355
Ø D		151	192	198	226	275	347	347	435	435	482	535	535	620	680	775	865	950	1025	1145	1276
Ø D ₁		-	-	-	-	275	345	345	430	430	480	530	530	620	680	770	860	945	1020	1140	1280
E		2	2	2	2	2	3	3	3	3	3	3	3	5	5	5	10	10	10	10	
E ₁		-	-	-	-	7	9	7	10,5	9	11,5	12	14	14	14,5	17	18,5	24	24	27	28
Ø F ₁		-	-	-	14	14	14	14	22	22	30	30	30	30	40	45	45	65	65	65	75
Ø F ₂	12 x 30°	9 (6)	10 (6)	10	10	12	15	15	18	18	22	25	25	25	30	35	40	45	45	50	55
Ø F ₃	12 x 30°	-	-	-	-	7	8,5	8,5	10,5	10,5	12,5	15	15	15	17	21	25	25	25	28	33
G		42	50	46	58	66	82	82	100	112	125	125	140	160	185	205	230	248	260	295	330
Ø H		60	65	75	70	97	125	125	153	172	192	190	210	245	270	310	320	345	395	450	490
Ø H ₁		60	65	121	70	90	130	130	145	160	166	180	190	250	270	290	320	350	370	450	490
Ø I		35	47	51	47	65	81,5	81,5	109	129	142	133	156	192	214	240	256	285	319	366	417
Ø J ₁		9	9,5	9	9,5	10,5	13,5	13,5	13,5	13,5	17	19	16,5	20	20	26	26	26	26	30	42
K ₁		-	-	20	20	20	20	20	25	25	25	25	25	25	35	35	35	45	45	45	60
K ₂		8	8	8	8	12	13	14	16	16	20	20	23	24	28	38	43	45	45	50	42
L ₁		-	-	25	28	28	28	28	45	45	60	60	60	60	80	90	90	130	130	130	150
M ₁		-	-	-	-	20	27	26,5	33	47	50	38,5	55	63	79	85	95	99	103	120	131
M ₂		13	15	12	18	20	24	26,5	31,5	47	50	32	55	63	79	85	95	99	103	120	131
N ₁		5	6	6	9	11	14	14	14,5	16	18	17	22	25	27	29	34	38	42	46	52
N ₂		-	-	-	-	11	14,5	14	15	16	18	21	22	25	27	29	34	38	42	46	52
Ø O	2 x 180°	4	5	4	6	6	10	10	12	13,5	14	14	16	18	20	21	23	25	32	32	35
P ₂		-	-	21	16	30,5	34	39	38	40	47	59	56	67,5	68,5	80,5	95	94	102	118	138,5
Ø R ₁		-	-	4,5	4,5	4,5	4,5	4,5	5,5	5,5	5,5	5,5	5,5	5,5	6,5	6,5	6,5	8,5	8,5	8,5	10,5
Ø R ₂	12 x 30°	M4 (6)	M5(6)	M5	M5	M6	M8	M8	M10	M10	M12	M14	M14	M14	M16	M20	M24	M24	M24	M27	M30
S		30	38	38	38	46	56	56	70	70	75	75	75	84	96	110	120	138	138	138	138
S ₁		6	5,8	5,8	5,8	6,5	9,5	9,5	10,5	10,5	13,5	13,5	13,5	17	17	20	21	24	24	24	24
Ø T ₁		-	-	337	361	446	527	527	680	680	775	855	855	950	1075	1220	1335	1595	1670	1790	2015
Ø U ₁		-	-	11	11	11	11	11	16	16	20	20	20	20	27	29,5	29,5	43,5	43,5	43,5	52,5
W		M5	M5	M6	M6	M6	M8	M8	M8	M8	M10	M12	M12	M16	M16	M16	M16	M18	M18	M20	M24
Ø Y		35	47	67	47	113	146	146	182	205	240	226,5	268	290	329	373	420	470	555	627	696
Z		12	16	15	17	18,5	21	23	26	27	30	31	33	37,5	44	47	55	60	68	76	85
Ta ₁	Nm	6,6	6,6	6,6	6,6	11	27,5	27,5	54	54	54	95	95	148	230	230	450	780	780	780	1500
Ta ₂		2,9	6	6	6	10	25	25	49	49	86	135	135	135	210	410	710	710	710	1050	1450

(*) Space to indicate the size
(*) Espacio para indicar el tamaño

ASSEMBLY EXAMPLES / EJEMPLOS DE MONTAJE

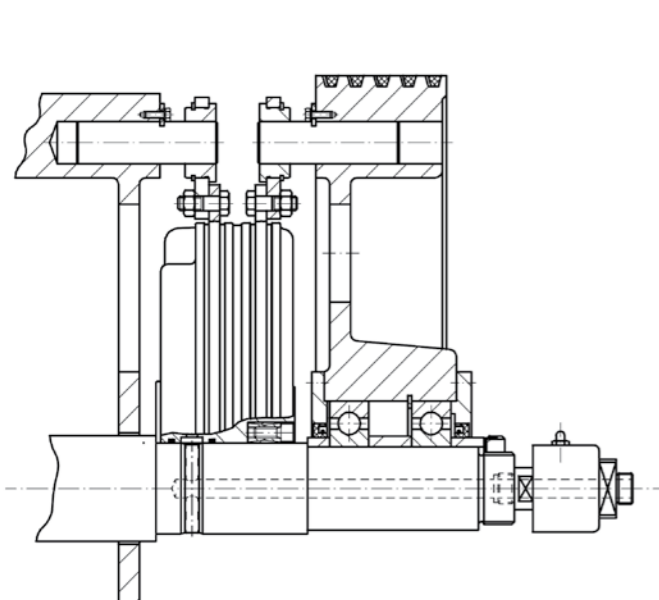

Series 5.71. __.WD

Mounting between frame and flywheel by means of identical pins on the clutch side and on the brake side. Fixed to the shaft by locking ring.

Montaje entre bastidor y volante con bulones iguales en el lado embrague y lado freno. Montado en el eje con anillo de fijación.

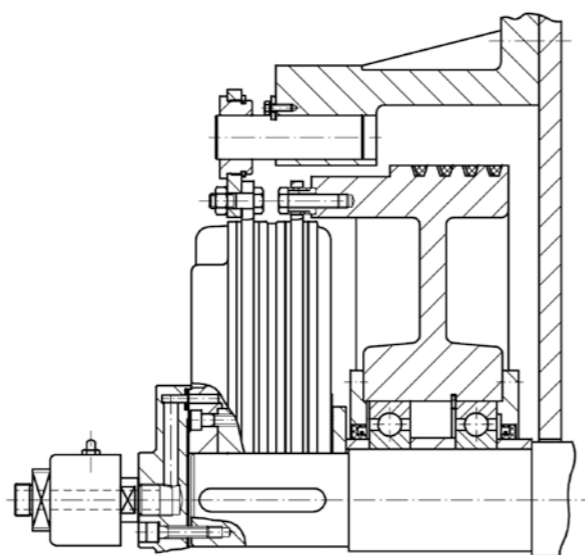

Series 5.72. __.AD

Mounting by means of 12 bushings on the clutch side and two pins on the brake side. Lateral air feeding.

Montaje en el extremo del eje con 12 casquillos en el lado embrague y dos bulones en el lado freno. Alimentación lateral de aire.

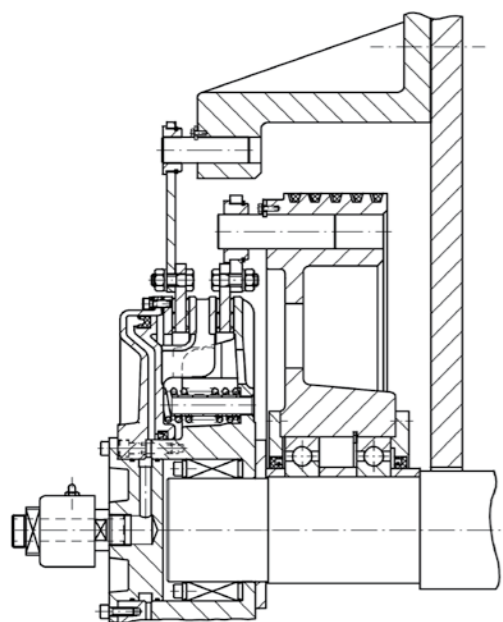

Series 5.74. __. CD (*)

Mounting at shaft end by means of pins on different diameters on both clutch and brake side. Fixed in the shaft by locking ring. Special air feeding, via air inlet block.

Montaje en el extremo del eje con bulones del lado embrague y lado freno situados en diámetros distintos. Montado en el eje con anillo de fijación. Alimentación de aire especial.

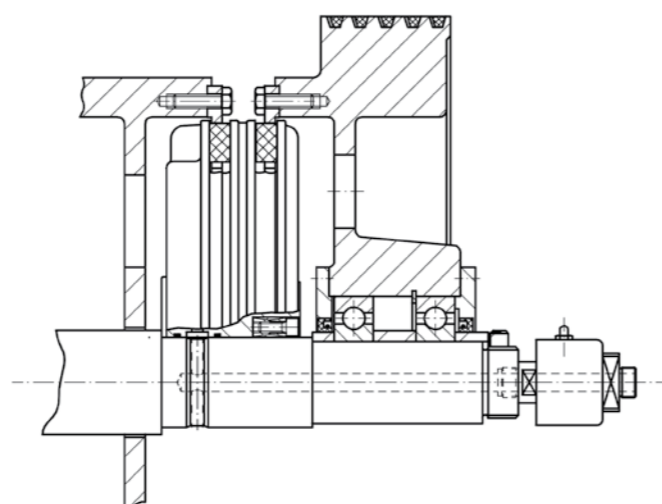

Series 5.75. __. WA

Mounting between frame and flywheel by means of pads in both clutch and brake side. Fixed to the shaft by locking ring.

Montaje entre bastidor y volante con tacos en ambos lados. Montado en el eje con anillo de fijación.

(*) If you are interested in CD type, please consult to GOIZPER
(*) En el caso de estar interesado en el tipo CD, consulte con GOIZPER

Torque Ratings 5.7 / Rango de Pares 5.7

SIZE	QUANTITY OF SPRINGS	BRAKE TORQUE (N.m)	CLUTCH TORQUE (N.m)	
			5,5 bar	6 bar
5	8	28	65	75
11	10	75	175	200
16	16	125	205	235
	14	110	220	250
	12	90	240	270
23	8	62	270	300
	12	185	265	310
	9	135	315	360
50	6	92	365	405
	10 + 10	490	695	805
	10 + 5	385	805	915
	10 + 0	275	920	1030
10	5 + 5	245	950	1060
	12 + 12	1030	1465	1695
	12 + 6	860	1645	1875
13	12 + 0	690	1820	2050
	6 + 6	515	1995	2225
	12 + 12	1030	1465	1695
18	12 + 6	860	1645	1875
	12 + 0	690	1820	2050
	6 + 6	515	1995	2225
	12 + 12	1960	2760	3190
19N	12 + 8	1690	3040	3480
	9 + 6	1265	3480	3910
	6 + 6	980	3770	4200
25N	16	2495	3430	3980
	14	2180	3755	4300
	12	1870	4080	4625
36	8	1245	4730	5275
	16	3410	4785	5540
	14	2985	5225	5980
	12	2555	5665	6420
37N	8	1700	6545	7200
	18	4060	5710	6620
	15	3380	6410	7310
55	12	2710	7110	8010
	9	2030	7810	8710
	16	4780	6720	7785
75	14	4180	7340	8400
	12	3585	7965	9025
	8	2380	9200	10270
	16	8000	9500	11100
76	14	7000	10500	12200
	12	6000	11600	13200
	8	4000	13600	15300
77	16	10000	13400	15600
	14	8700	14700	16900
	12	7500	16000	18200
78	8	5000	18600	20700
	16 + 16	15800	19100	22300
	14 + 14	13500	21400	24700
80	10 + 10	9900	25300	28500
	8 + 8	7900	27300	30500
	18	20500	29300	34000
81	15	17100	32900	37500
	12	13700	36500	41100
	9	10250	40000	44700
82	20 + 20	27600	39000	45200
	20 + 10	23600	43200	49400
	16 + 4	17500	49500	55600
	10 + 10	13800	53400	59500
80	24 + 24	36000	50000	58000
	20 + 20	30000	56500	64500
	16 + 16	24000	63000	71000
81	12 + 12	18000	69000	77500
	24 + 24	50000	70000	81000
	20 + 20	41000	79000	90000
82	16 + 16	33000	87000	99000
	12 + 12	25000	96000	107000
	24 + 24	71500	98000	113500
	20 + 20	59500	110500	126000
80	16 + 16	47500	122500	138500
	12 + 12	35500	135000	151000

CLUTCH-BRAKES SERIES 5.0

FRENO-EMBRAGUES SERIE 5.0

Series 5.0 is the latest version of our traditional design of clutch-brakes assembled with pins that tighten both covers to avoid deformation and failure due to stress.

The brake side cover is manufactured in aluminium, obtaining a low inertia.

Los freno-embragues de la serie 5.0 son la última versión de nuestro tradicional diseño de freno embragues ensamblados por tirantes, los cuales atan ambas tapas para evitar deformaciones y roturas por fatiga.

Otra de sus características es que la tapa lado freno es de aluminio con lo que se consigue una baja inercia.

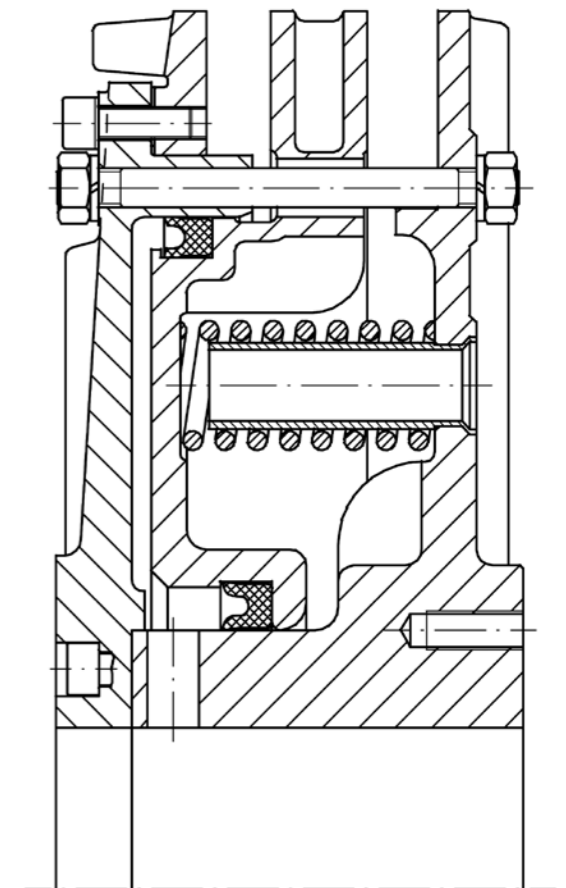

Series 5.01.*.WD

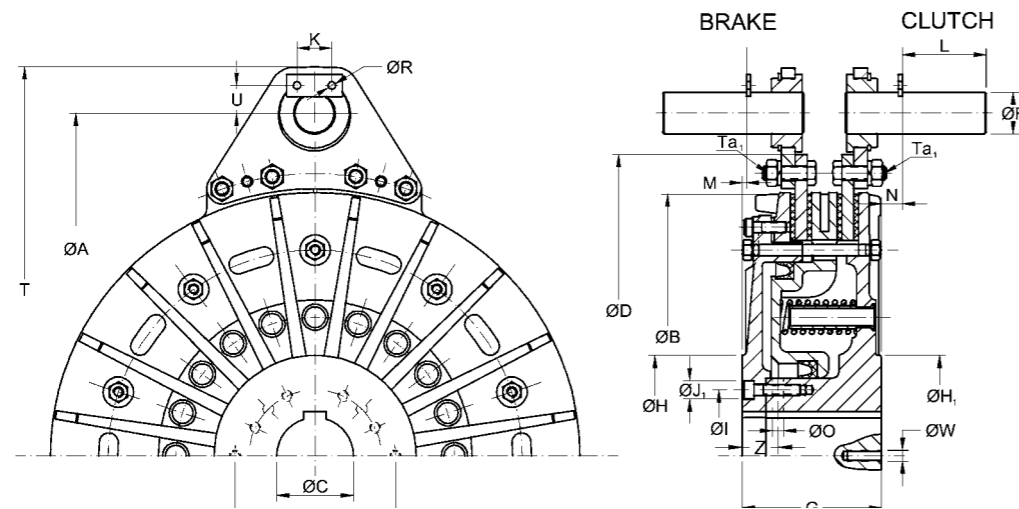

Series 5.02.*.WD

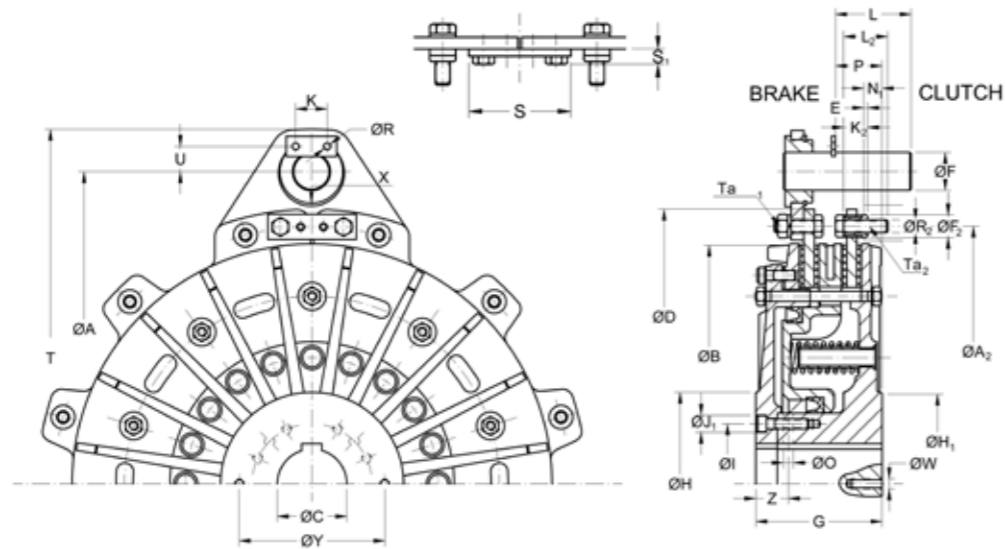

Series 5.04.*.WD

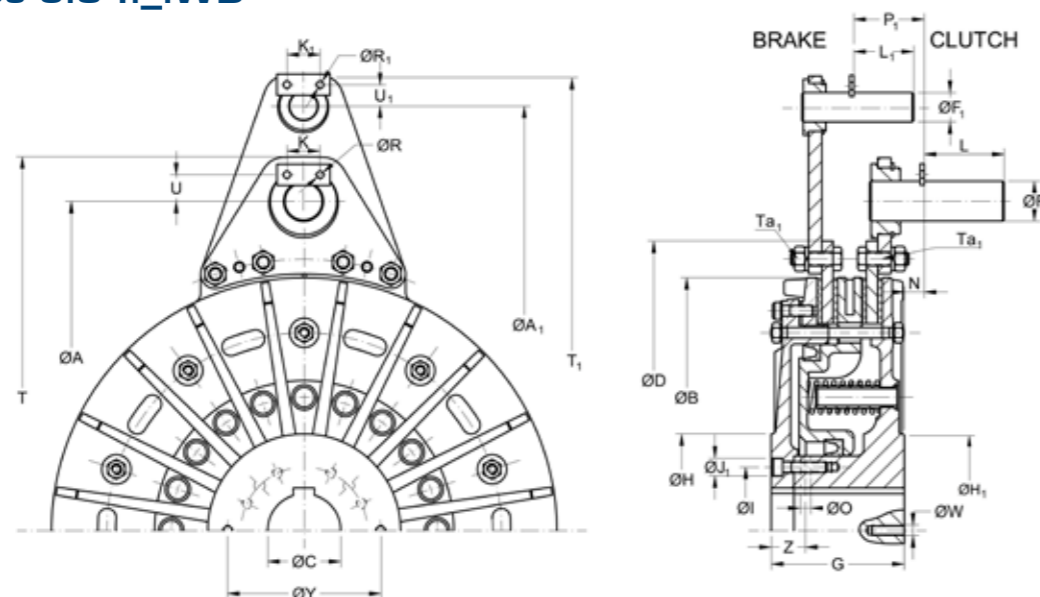

SERIES		5.01._WD / 5.02._WD / 5.04._WD									
SIZE		60	10	18	36	55	75	76	77	78	79
Clutch torque	Nm	690	1100	2100	4500	7000	10200	14300	19200	30800	45100
Brake torque		430	585	1370	2930	4250	5900	8700	11500	17700	27800
Pressure	bar	5,5									
Max speed	min ⁻¹	2300	1750	1450	1200	1000	900	800	760	600	450
Weight	501 WD	16	24	43	79	122	175	238	324	537	850
	502 WD	15	23	41	77	117	163	229	312	515	-
	504 WD	16	24	43	79	122	175	238	324	537	-
J. int.	Kg m ²	0,08	0,19	0,46	1,23	2,73	4,55	7,37	13,25	29,88	62
J. ext.	501 WD	0,043	0,114	0,274	0,768	1,354	2,144	4,57	7,51	16,78	32
	502 WD	0,027	0,062	0,202	0,53	1,044	1,555	3,342	6,51	12,6	-
	504 WD	0,043	0,114	0,274	0,768	1,354	2,144	4,57	7,51	16,78	-
New vol	dm ³	0,136	0,23	0,482	0,797	1,15	1,47	2,25	2,83	5,37	7,3
Max. wear Volum.		0,255	0,385	0,792	1,37	1,9	2,44	3,86	4,98	8,7	11
Ø A		345	390	495	610	695	770	880	970	1140	1300
Ø A1		440	490	635	790	885	990	1135	1235	1450	-
Ø A2		283	325	408	500	584	640	725	810	945	1080
Ø B		265	305	380	466	542	599	675	755	885	1000
Ø C (H7)	Min.	32	35	45	50	60	60	75	90	115	140
	Max.	52	65	80	108	114	125	145	160	180	220
Ø D		305	347	435	535	620	680	775	865	1000	1145
E		2	3	3	3	5	5	5	5	5	-
Ø F		22	22	30	40	40	45	55	55	65	75
Ø F ₁		14	14	22	30	30	40	45	45	55	-
Ø F ₂		12	15	18	25	25	30	35	40	42	-
G		72	82	100	125	145	160	185	203	255	295
Ø H		105	125	145	190	206	225	265	276	300(330)	376
Ø H ₁		110	130	145	180	200	220	265	276	300	376
Ø I		66	82	95	123	136	150	168	186	212	290
Ø J ₁		10,5	10,5	13,5	13,5	16,5	16,5	18,5	22,5	28	32
K		25	25	25	35	35	35	45	45	45	60
K ₁		20	20	25	25	25	35	35	35	45	-
K ₂		14	17	19	25	30	32	36	40	48	-
L		45	45	60	80	80	90	110	110	130	150
L ₁		28	28	45	60	60	80	90	90	110	-
L ₂		25	30	35	45	50	60	70	80	90	-
M		1	1	3	4	4	8	8	14	20	57,5
N		10	12,5	15	15	15	17,5	20	20	20	16,5
N ₁		12	14	14,5	17	19	20	22	25	33	-
Ø O		8	10	12	14	16	16	20	20	28	32
P		27	27	39	58	61	58	83	94	114	-
P ₁	12 x 180°	39	46,5	53	74	86	84	103	115	147	-
Ø R		5,5	5,5	5,5	6,5	6,5	6,5	8,5	8,5	8,5	10,5
	Ø R ₁	4,5	4,5	5,5	5,5	5,5	6,5	6,5	6,5	8,5	-
	Ø R ₂	M6	M8	M10	M14	M14	M16	M20	M24	M24	-
S		46	56	70	75	84	96	110	120	138	-
S ₁		6,5	9,5	10,5	13,5	17	17	20	21	24	-
T		390	435	560	695	780	870	1000	1090	1285	1460
T ₁		475	527	680	855	950	1075	1220	1335	1570	-
U		16	16	20	27	27	29,5	38,5	38,5	43,5	51
U ₁		11	11	16	20	20	27	29,5	29,5	38,5	-
W		M8	M8	M8	M10	M12	M12	M14	M16	M18	-
Ø Y		66	82	115	145	160	170	210	220	250	-
Z		20	21	26	31	36,5	41	48	53	67	76
Ta ₁	Nm	11	27,5	54	95	148	230	230	450	450	780
Ta ₂		10	25	49	135	135	210	410	710	710	-

(*) Space to indicate the size
 (*) Espacio para indicar el tamaño

Series 5.05.*.WD

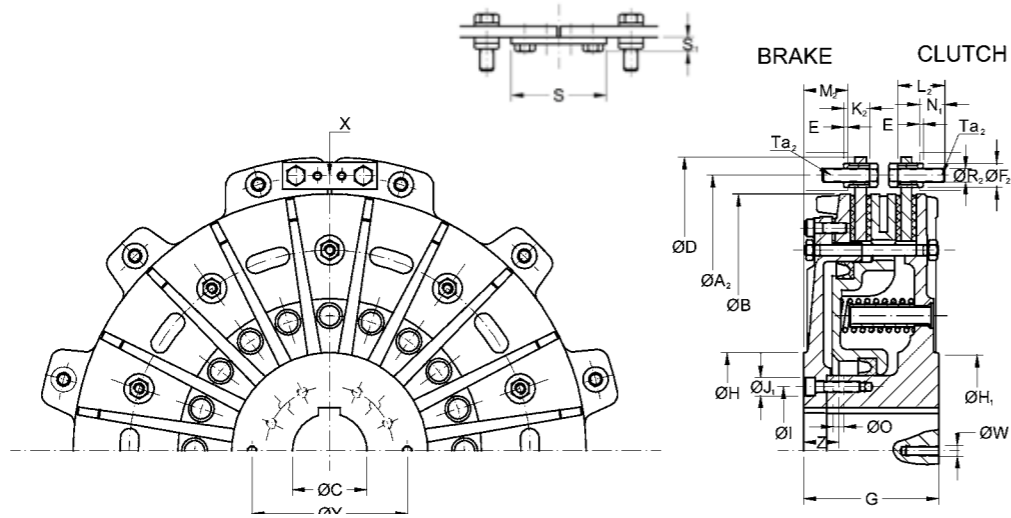

Series 5.05.*.WA

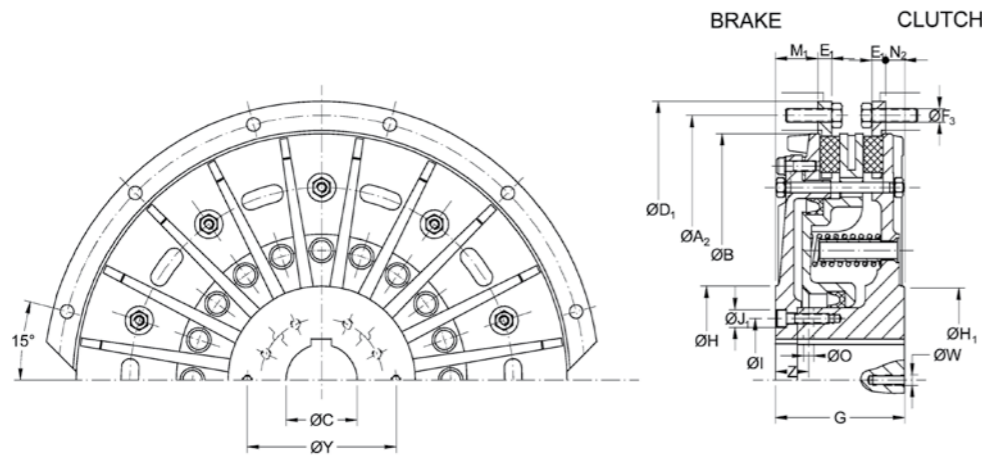

Series 5.06.*.WD

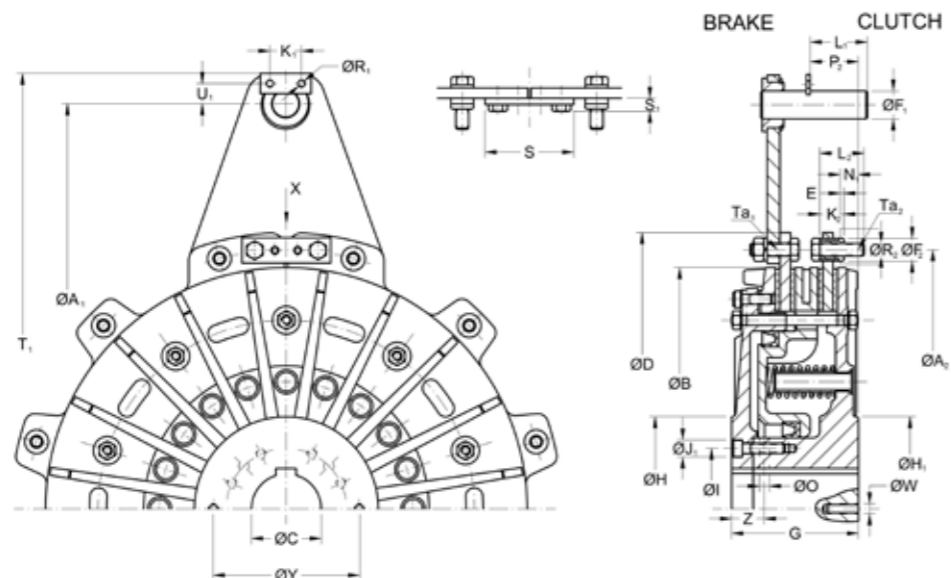

(*) Space to indicate the size
 (*) Espacio para indicar el tamaño

PNEUMATIC CLUTCH-BRAKES / FRENO-EMBRAGUES NEUMÁTICOS

SERIES		5.05.*.WD / 5.05.*.WA / 5.06.*.WD									
SIZE		60	10	18	36	55	75	76	77	78	79
Clutch torque	Nm	690	1100	2100	4500	7000	10200	14300	19200	30800	45100
Brake torque		430	585	1370	2930	4250	5900	8700	11500	17700	27800
Pressure	bar	5,5									
Max speed	min ⁻¹	2300	1750	1450	1200	1000	900	800	760	600	450
Weight	505 WD	14	22	39	73	111	153	220	301	494	850
	505 WA	-	22	41	75	112	159	230	292	482	-
	506 WD	15	23	41	77	117	163	229	312	515	-
J. int.	Kg m ²	0,08	0,19	0,46	1,23	2,73	4,55	7,37	13,25	29,88	62
J. ext.	501 WD	0,027	0,062	0,202	0,53	1,044	1,555	3,342	6,513	12,6	32
	502 WD	-	0,045	0,131	0,341	0,881	1,261	2,24	3,87	8,46	-
	504 WD	0,027	0,062	0,202	0,53	1,044	1,555	3,342	6,513	12,6	-
New vol.	dm ³	0,136	0,23	0,482	0,797	1,15	1,47	2,25	2,83	5,37	7,3
Max. wear Vol.		0,255	0,385	0,792	1,37	1,9	2,44	3,86	4,98	8,7	11
Ø A1		440	490	635	790	885	990	1135	1235	1450	-
Ø A2		283	325	408	500	584	640	725	810	945	1080
Ø B		265	305	380	466	542	599	675	755	885	1000
Ø C (H7)	Min.	32	35	45	50	60	60	75	90	115	140
	Max.	52	65	80	108	114	125	145	160	180	220
Ø D ₁		-	345	430	530	620	680	770	860	995	-
Ø D		305	347	435	535	620	680	775	865	1000	1145
E		2	3	3	3	5	5	5	5	5	-
E ₁		-	9	10,5	12	16	16,5	17	18,5	24	-
Ø F ₁	12 x 30°	14	14	22	30	30	40	45	45	55	-
Ø F ₂		12	15	18	25	25	30	35	40	42	-
Ø F ₃		-	8,5	10,5	15	15	17	21	25	25	-
G		72	82	100	125	145	160	185	203	255	295
Ø H		105	125	145	190	206	225	265	276	300(330)	376
Ø H ₁		110	130	145	180	200	220	265	276	300	376
Ø I		66	82	95	123	136	150	168	186	212	290
Ø J ₁		10,5	10,5	13,5	13,5	16,5	16,5	18,5	22,5	28	32
K ₁		20	20	25	25	25	35	35	35	45	-
K ₂		14	17	19	25	30	32	36	40	48	-
L ₁		28	28	45	60	60	80	90	90	110	-
L ₂		25	30	35	45	50	60	70	80	90	-
M ₁		-	27	33	38,5	45,5	57	59	66	83,5	-
M ₂		21	24	31,5	32	41	50	50	57	73	-
N ₁		11	12	14,5	17	19	20	22	25	33	-
N ₂		-	14,5	15	21	24,5	26	31	34	42,5	-
Ø O	2 x 180°	8	10	12	14	16	16	20	20	28	32
P ₂		29	34	38	59	71	66,5	83	95	127	-
Ø R ₁	12 x 30°	4,5	4,5	5,5	5,5	5,5	6,5	6,5	6,5	8,5	-
Ø R ₂		M6	M8	M10	M14	M14	M16	M20	M24	M24	-
S		46	56	70	75	84	96	110	120	138	-
S ₁		6,5	9,5	10,5	13,5	17	17	20	21	24	-
T ₁		475	527	680	855	950	1075	1220	1335	1570	-
U ₁		11	11	16	20	20	27	29,5	29,5	38,5	-
W		M8	M8	M8	M10	M12	M12	M14	M16	M18	-
Ø Y		66	82	115	145	160	170	210	220	250	-
Z		20	21	26	31	36,5	41	48	53	67	76
Ta ₁	Nm	11	27,5	54	95	148	230	230	450	450	780
Ta ₂		10	25	49	135	135	210	410	710	710	-

ASSEMBLY EXAMPLES / EJEMPLOS DE MONTAJE

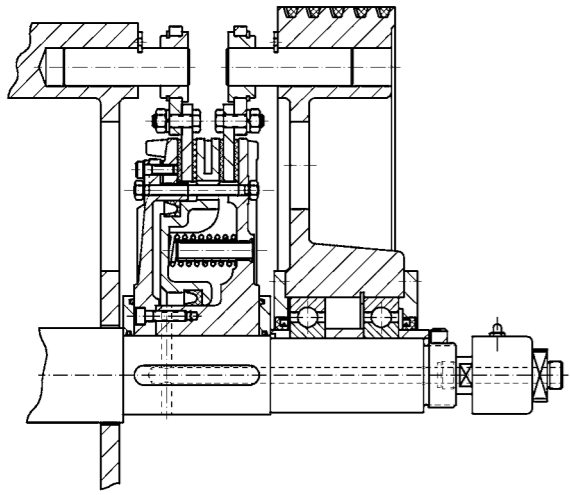

Series 5.01. __. WD

Mounting between frame and flywheel by means of identical pins in both clutch and brake side.

Montaje entre bastidor y volante con bulones iguales en el lado embrague y lado freno.

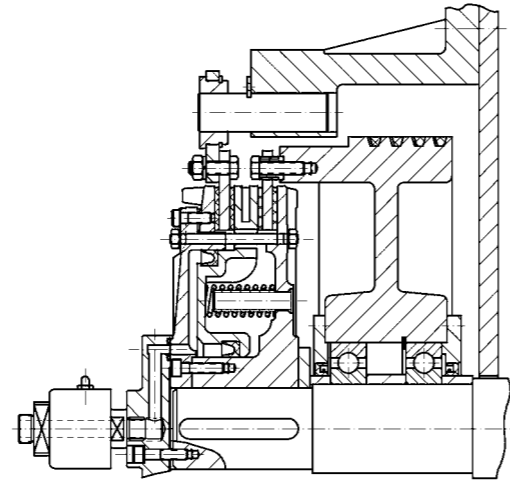

Series 5.02. __. AD

Mounting at shaft end by means of 12 bushings on the clutch side and two pins on the brake side.

Montaje entre bastidor y volante con 12 casquillos en el lado embrague y dos bulones en el lado freno. Alimentación lateral de aire

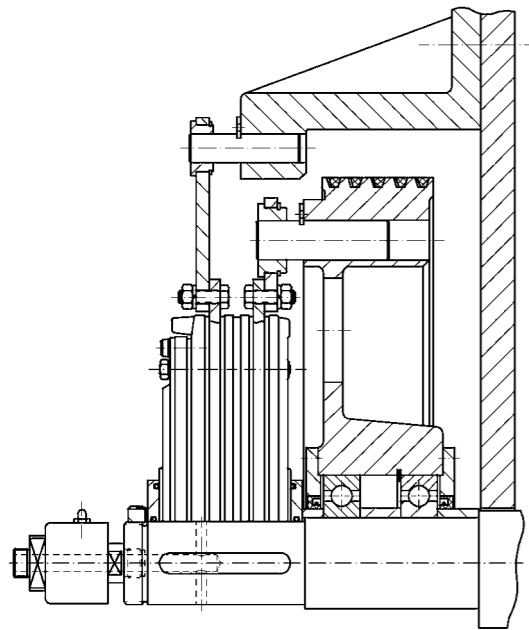

Series 5.04. __. WD

Mounting at shaft end by means of pins on different diameters on both clutch and brake side.

Montaje en extremo de eje con bulones del lado embrague y lado freno situados en diámetros distintos.

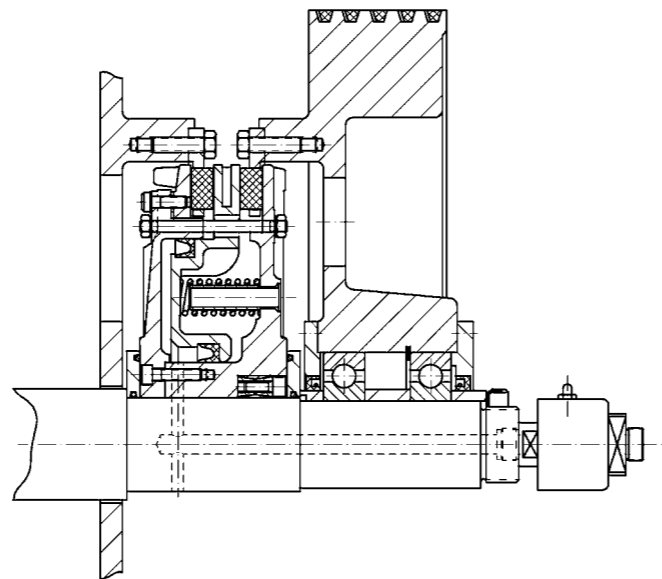

Series 5.05. __. WA

Mounting between frame and flywheel by means of pads in both clutch and brake side. Fixed in the shaft by locking ring.

Montaje entre bastidor y volante con tacos en ambos lados. Montado en el eje con anillo de fijación.

Torque Ratings 5.0 / Rango de Pares 5.0

SIZE	QUANTITY OF SPRINGS	BRAKE TORQUE (N.m)	CLUTCH TORQUE (N.m)	
			5,5 bar	6 bar
60	12	430	690	800
	9	320	800	900
	6	215	900	1000
10	18	585	1100	1200
	15	485	1200	1300
	12	390	1300	1400
18	9	290	1400	1500
	16	1370	2100	2400
	12	1025	2400	2800
36	10	855	2600	2900
	8	685	2800	3100
	18	2930	4500	5200
55	15	2445	5000	5700
	12	1955	5500	6200
	9	1465	6000	6700
75	18	4250	7000	8000
	15	3550	7700	8700
	12	2850	8400	9500
76	9	2125	9200	10200
	24	5900	10200	11700
	20	4900	11200	12700
77	16	3900	12300	13800
	12	2950	13300	14800
	18	8700	14300	16500
78	15	7200	15800	18000
	12	5800	17400	19500
	9	4300	18900	21000
79	18	11500	19200	22000
	15	9600	21200	24000
	12	7700	23200	26000
78	9	5750	25200	28000
	18	17700	30800	35300
	15	14800	33900	38300
79	12	11800	36900	41400
	9	8850	40000	44400
	18	27800	45100	51800
79	15	23200	49900	56700
	12	18500	54700	61500
	9	13900	59600	66300

CLUTCH-BRAKES SERIES 5.5 and 5.6

FRENO-EMBRAGUES SERIE 5.5 y 5.6

Series 5.5 corresponds to clutch-brakes with double disc in the clutch side, in order to get a lower inertia. Their external covers and hubs are made of electro-welded steel.

La serie 5.5 corresponde a las ejecuciones de freno-embrague con doble disco en el lado del embrague, con objeto de conseguir una menor inercia. Sus tapas exteriores y moyús están fabricados en acero electrosoldado.

Series 5.6 is similar to 5.5 but has double disc in both sides, improving the torque-inertia rate.

La serie 5.6 es similar a la 5.5, pero se diferencia en que lleva doble disco tanto en el lado del embrague como en el del freno con lo que la relación par-inercia mejora.

Series 5.5

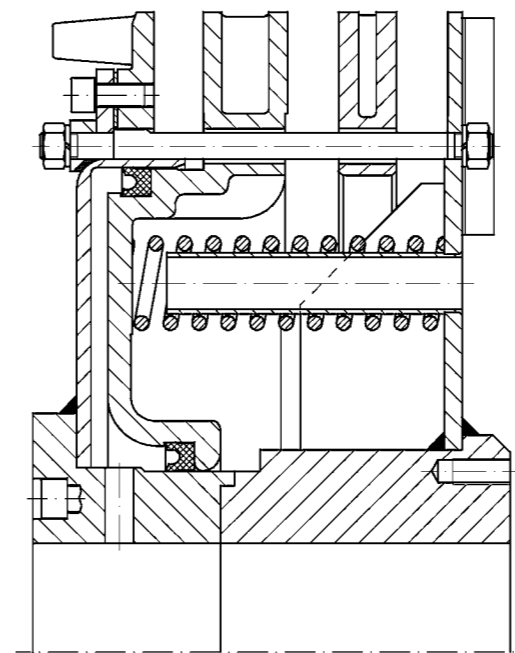

Series 5.6

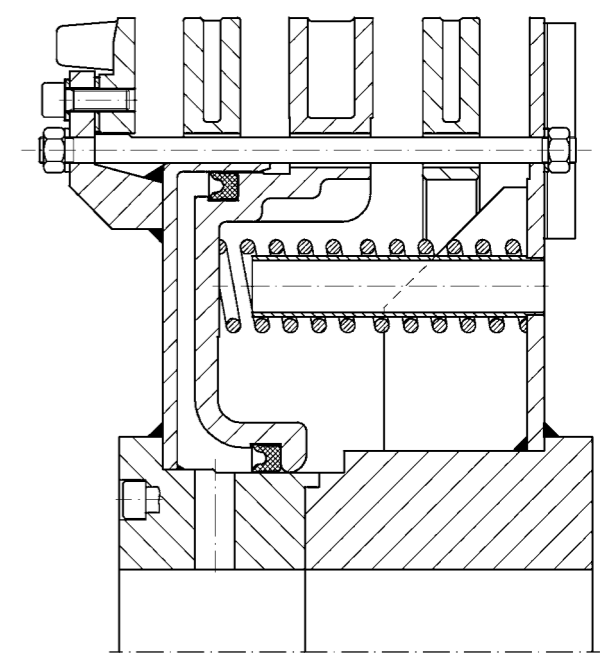

Series 5.51.*.WD

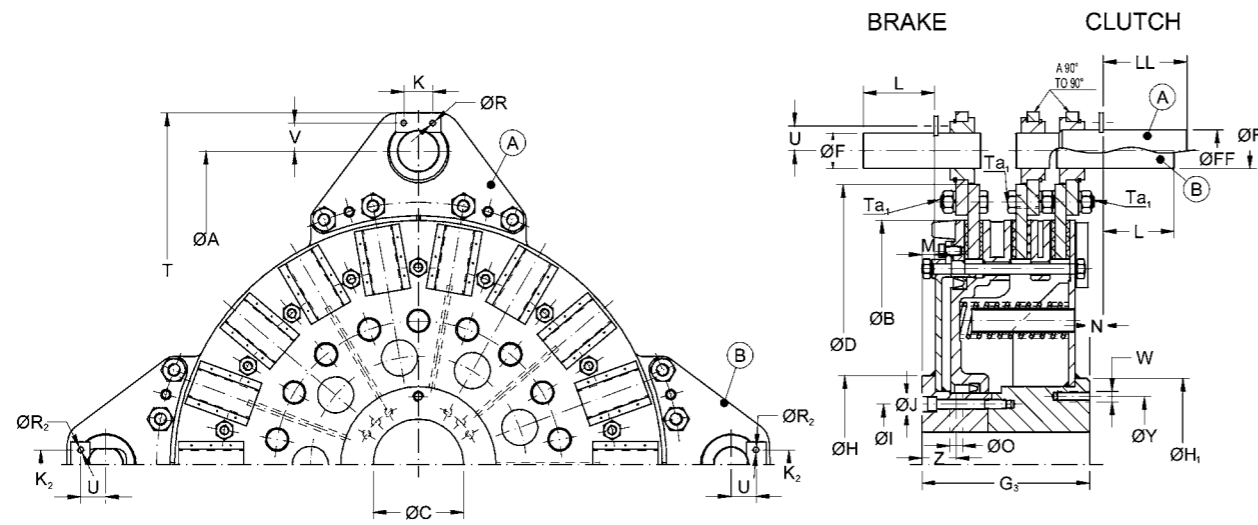

Series 5.54.*.WD

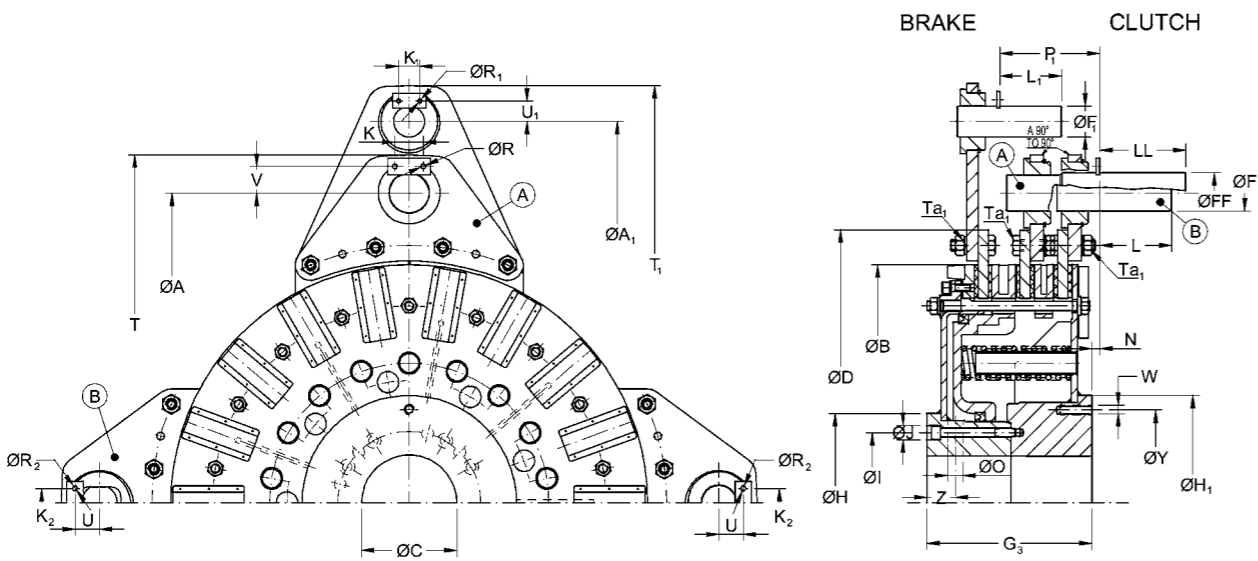

PNEUMATIC CLUTCH-BRAKES / FRENO-EMBRAGUES NEUMÁTICOS

SERIES		5.51._.WD / 5.54._.WD								
SIZE		18	36	55	75	76	77	78	79	81
Clutch torque	Nm	4200	9000	14000	20400	28600	38400	61600	90200	138000
Brake torque		1370	2930	4250	5900	8700	11500	17700	27800	35500
Pressure	bar	5,5								
Max speed	min ⁻¹	1400	1100	950	850	750	700	550	400	350
Weight	Kg	66	112	158	211	313	424	722	1120	1680
J. int.	Kg m ²	0,71	1,83	3,2	5,9	10,4	17,7	39	80	155
ext.		0,637	1,775	3	4,745	10,1	16,27	36,36	65	150
New vol	dm ³	0,7	1,1	1,5	1,9	2,4	2,9	4,3	6	10,9
Max. wear Volum.		1,2	2,2	3	3,9	5,2	6,8	10,3	13	17,5
Ø A		495	610	695	770	880	970	1140	1300	1465
Ø A ₁		635	790	885	990	1135	1235	1450	-	1855
Ø B		380	466	542	599	675	755	885	1000	1140
Ø C (H7)	Min.	45	50	60	60	75	90	115	140	150
	Max.	80	108	114	125	145	160	180	220	260
Ø D		435	535	620	680	775	865	1000	1145	1276
Ø F		30	40	40	45	55	55	65	75	90
Ø F ₁		22	30	30	40	45	45	55	-	75
Ø FF		40	50	50	55	65	65	75	85	100
G ₃		134	169	190	209	242	260	331	361	400
Ø H		140(145)*	160(190)*	180(206)*	190(225)*	225(265)*	240(276)*	300(330)*	376	428
Ø H ₁		140	160	180	190	225	240	300	376	428
Ø I		95	123	132	150	168	186	212	300	340
Ø J		13,5	13,5	17	17	18,5	22,5	28	32	40
K		35	35	35	45	45	45	45	60	60
K ₁		25	25	25	35	35	35	45	-	60
K ₂		25	35	35	35	45	45	45	60	60
L		60	80	80	90	110	110	130	150	180
L ₁		45	60	60	80	90	90	110	-	150
LL		80	100	100	110	130	130	160	180	210
M		4	6	7,5	12,5	14	14	20	57,5	57,5
N		15	15	15	17,5	20	20	20	16,5	19,5
Ø O	2 x 180°	12	14	16	16	20	20	28	32	35
P ₁		90	120	133	135	160	174	225	-	217,5
Ø R		6,5	6,5	6,5	8,5	8,5	8,5	8,5	10,5	10,5
Ø R ₁		5,5	5,5	5,5	6,5	6,5	6,5	8,5	-	10,5
Ø R ₂		5,5	6,5	6,5	6,5	8,5	8,5	8,5	-	10,5
T		560	695	780	870	1000	1090	1285	1460	1650
T ₁		680	855	950	1 075	1220	1335	1570	-	2015
U		20	27	27	29,5	38,5	38,5	43,5	51	60
U ₁		16	20	20	27	29,5	29,5	38,5	-	52,5
V		27	32	32	38,5	43,5	43,5	48,5	-	65
W		M8	M12	M12	M12	M16	M16	M18	-	24
Ø Y		110	132	155	165	185	210	250	-	340
Z		26	31	36,5	41	48	53	67	76	85
Ta ₁	Nm	54	95	148	230	230	450	450	780	1590

(*) Space to indicate the size
(*) Espacio para indicar el tamaño

(*) The measurements between brackets are in the case of lateral air feeding.
(*) El valor entre paréntesis es para casos de entrada lateral de aire.

Series 5.61.*.WD

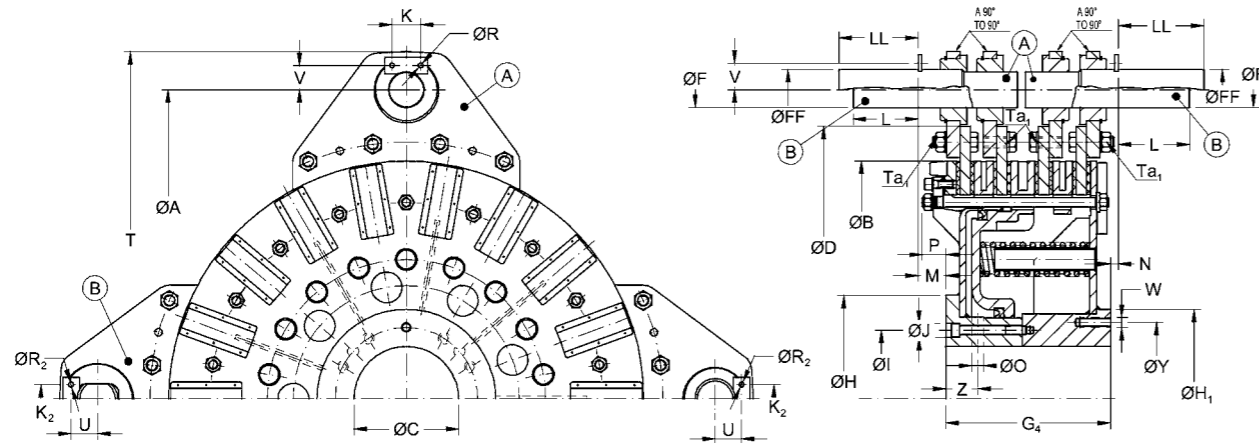

Series 5.64.*.WD

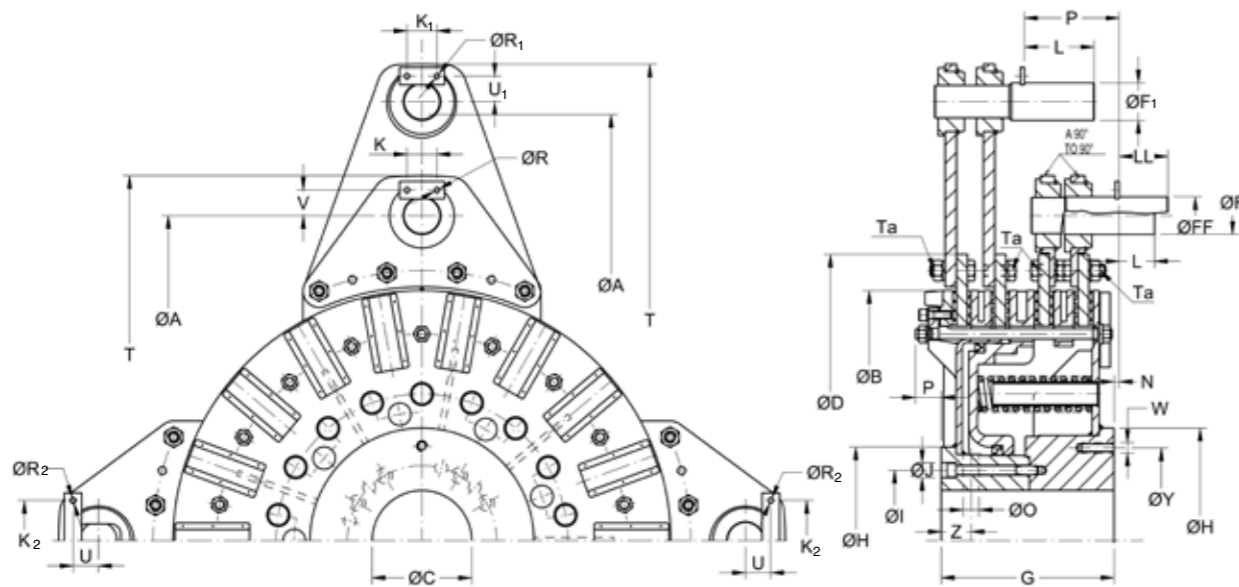

(*) Space to indicate the size
(*) Espacio para indicar el tamaño

PNEUMATIC CLUTCH-BRAKES / FRENO-EMBRAGUES NEUMÁTICOS

SERIES		5.61.__.WD / 5.64.__.WD								
SIZE		18	36	55	75	76	77	78	79	81
Clutch torque	Nm	4200	9000	14000	20400	28600	38400	61600	90200	138000
Brake torque		2740	5860	8500	11800	17400	23000	35400	55600	71000
Pressure	bar	5,5								
Max speed	min ⁻¹	1400	1100	950	850	750	700	550	400	350
Weight	Kg	66	138	194	257	377	519	880	1340	1900
J. int.	Kg m ²	0,71	2,3	4	7,4	12,6	22,1	49	99	190
ext.		0,63	1,77	3	4,74	10,1	16,27	36,36	65	140
New vol	dm ³	0,7	1,1	1,5	1,9	2,4	2,9	4,3	6	10,6
Max. wear Volum.		1,2	2,2	3	3,9	5,2	6,8	10,3	13	18,2
Ø A		495	610	695	770	880	970	1140	1300	1465
Ø A ₁		635	790	885	990	1135	1235	1450	1645	1855
Ø B		380	466	542	599	675	755	885	1000	1140
Ø C (H7)	Min. Max.	45 80	50 108	60 114	60 125	75 145	90 160	115 180	140 220	150 260
Ø D		435	535	620	680	775	865	1000	1145	1276
Ø F		30	40	40	45	55	55	65	75	90
Ø F ₁		30	50	50	55	65	65	75	75	75
Ø FF		40	50	50	55	65	65	75	85	100
G ₄		134	169	190	209	242	260	331	361	400
Ø H		140(145)*	160(190)*	180(206)*	190(225)*	225(265)*	240(276)*	300(330)*	376	428
Ø H ₁		140	160	180	190	225	240	300	376	428
Ø I		95	123	132	150	168	186	212	290	340
Ø J		13,5	13,5	17	17	18,5	22,5	28	32	40
K		25	35	35	45	45	45	45	60	60
K ₁		25	35	35	45	45	45	45	60	60
K ₂		35	35	35	35	45	45	45	60	60
L		60	80	80	90	110	110	130	150	180
L ₁		70	90	90	100	110	110	130	140	150
LL		80	100	100	110	130	130	160	180	210
M		33	38	38	38	48	48	58	-	30
N		15	15	15	17,5	20	20	20	16,5	19,5
Ø O	2 x 180°	12	14	16	16	20	20	28	32	35
P		28,5	39	36,5	35	41,5	47	56,5	-	50
P ₁		90	120	133	135	160	174	225	200	217,5
Ø R		5,5	6,5	6,5	8,5	8,5	8,5	8,5	10,5	10,5
Ø R ₁		5,5	6,5	6,5	8,5	8,5	8,5	8,5	10,5	10,5
Ø R ₂		6,5	6,5	6,5	6,5	8,5	8,5	8,5	-	10,5
T		560	695	780	870	1000	1090	1285	1460	1650
T ₁		680	875	970	1075	1220	1355	1600	1795	2015
U		27	27	27	29,5	38,5	38,5	43,5	51	60
U ₁		20	32	32	38,5	43,5	43,5	48,5	51	52,5
V		20	32	32	38,5	43,5	43,5	48,5	51	65
W		M8	M12	M12	M12	M16	M16	M18	-	24
Ø Y		110	132	155	165	185	210	250	-	340
Z		26	31	36,5	41	48	53	67	76	85
Ta ₁	Nm	54	95	148	230	230	450	450	780	1590

(*) The measurements between brackets are in the case of lateral air feeding.
(*) El valor entre paréntesis es para casos de entrada lateral de aire.

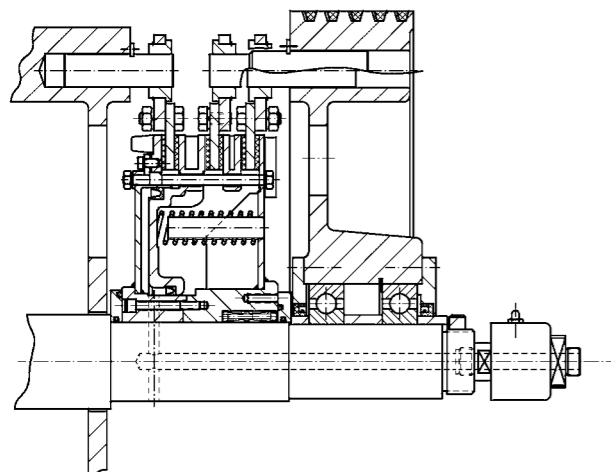

Series 5.51. __. WD

Mounting between frame and flywheel by means of 4 pins at 90° on the clutch side and 2 pins on the brake side all of them on the same diameter. Fixed in the shaft by locking ring.

Montaje entre bastidor y volante con 4 bulones a 90° en el lado embrague y 2 bulones en el lado freno situados todos ellos en el mismo diámetro. Montado en el eje con anillo de fijación.

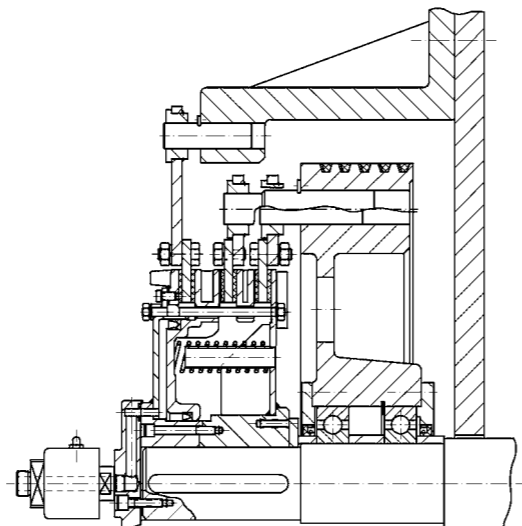

Series 5.54. __. AD

Mounting at shaft and by means of 4 pins at 90° on the clutch side and 2 pins on brake side on different diameters. Lateral air feeding.

Montaje en el extremo del eje con 4 bulones a 90° en el lado embrague y 2 bulones en el lado freno situados en diámetros distintos. Alimentación lateral de aire.

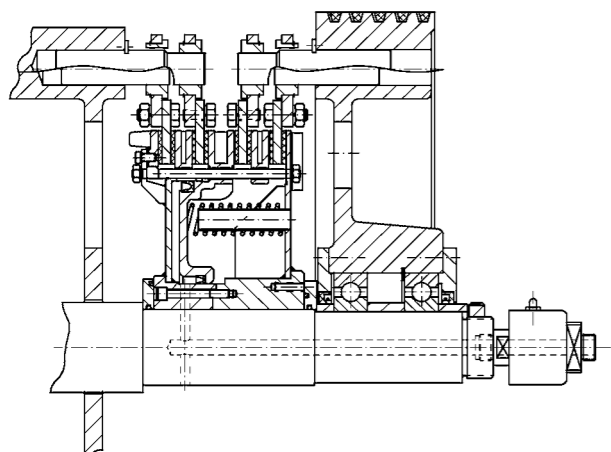

Series 5.61. __. WD

Mounting between frame and flywheel by means of 4 pins at 90° on the clutch side and 4 pins at 90° on the brake side, all of them on the same diameter.

Montaje entre bastidor y volante con 4 bulones a 90° en el lado embrague y 4 bulones a 90° en el lado freno, situados todos ellos en el mismo diámetro.

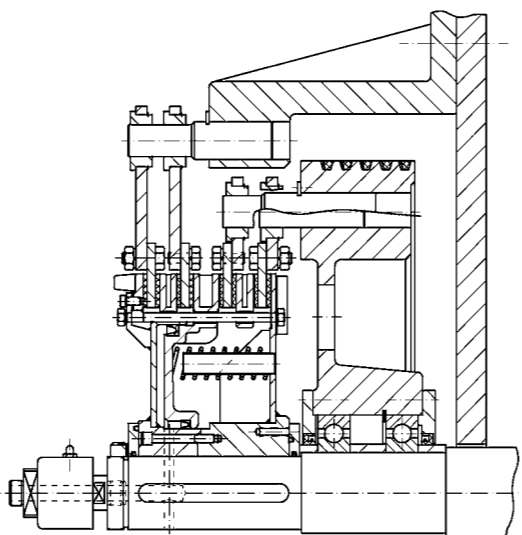

Series 5.64. __. WD

Mounting at shaft and by means of 4 pins at 90° on the clutch side and 2 pins connected to double discs on brake side, on different diameters.

Montaje en el extremo del eje con 4 bulones a 90° en el lado embrague y 2 bulones conectados a doble disco en el lado del freno, situados en diámetros distintos.

ACCESSORIES

ACCESORIOS

AIR INLET DISC

When the clutch-brake is mounted at the shaft end, it can be fed by a lateral air inlet.

In this way, the shaft is shorter and it eliminates the need to drill the shaft.

DISCO DE ALIMENTACIÓN LATERAL

En los casos en que el freno-embrague esté situado en el extremo del eje, puede ser alimentado por medio de un disco de alimentación lateral suministrado por GOIZPER y que va atado al eje por medio de 4 tornillos. De esta forma, el eje es más corto y se evita mecanizar los agujeros de alimentación de aire.

SERIES		5.7														
SIZE		50	10-13	18	19N	25N	36	37N	55	75	76	77	78	80	81	82
Ø A		101	128	156	175	196	193	214	250	275	315	312	346	395	448	502
Ø C	Min.	44	50	60	45	45	68	70	70	90	100	125	125	140	150	170
	Max.	52	65	90	95	100	110	115	130	155	172	180	200	220	240	270
Ø E		M 22 x 1,5			M 27 x 1,5				M 35 x 1,5		M 50 x 1,5			M 65 x 1,5		
G		31	31	34	34	34	37,5	37,5	39,5	47	47	47	53	60	60	66
H		1,5	2,5	3	3	3	3	3	3	3	3	3	3	3	3	3
L		16	16	20	20	20	25	25	35	35	35	35	35	35	35	41
Ø P		36	36	44	44	48	56	56	56	56	80	80	80	98	98	100
Ø S		10,5	10,5	13,5	13,5	13,5	16,5	16,5	18,5	18,5	25	25	25	25	25	25
Ø T - 4 x 90°		M 6	M 6	M 8	M 8	M 8	M 10	M 10	M 12	M 12	M 16	M 16	M 16	M 16	M 16	M 16
Ø U		52	52	65	65	70	80	80	80	112	112	112	112	132	132	135
Weight kg.		1	1,8	2,5	3,75	4,8	4,8	6	9,13	13,55	17,2	15,4	22	29,4	58,3	57
J kgm ²		0,0018	0,0044	0,0096	0,014	0,021	0,024	0,032	0,078	0,136	0,232	0,209	0,317	0,596	0,88	1,644

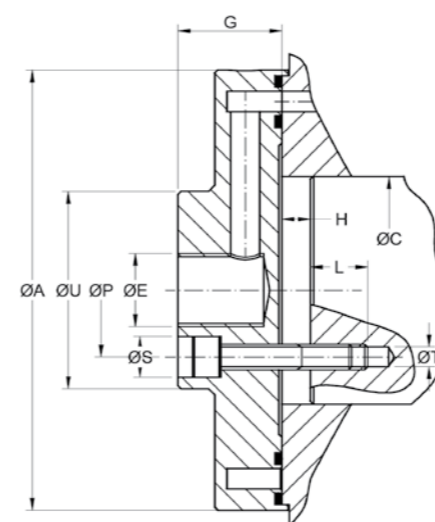

SERIES		5.0								
SIZE		60	10	18	36	55	75	76	77	78
Ø A		105	126	145	188	205	225	265	275	330
Ø C	Min.	44	44	55	68	70	70	75	100	115
	Max.	52	65	80	108	114	125	145	160	180
Ø E		M 22 x 1,5		M 27 x 1,5		M 35 x 1,5			M 50 x 1,5	
G		31	31	34	37,5	39,5	41	44	47	53
H		1,5	2,5	3	3	3	3	3	3	3
L		16	16	20	25	35	35	35	35	35
Ø P		36	36	44	56	56	56	56	80	80
Ø S		10,5	10,5	13,5	16,5	18,5	18,5	18,5	25	25
Ø T - 4 x 90°		M 6	M 6	M 8	M 10	M 12	M 12	M 12	M 16	M 16
Ø U		52	52	65	80	80	80	80	112	112
Weight kg.		1,1	1,8	2,3	4,6	5,5	6,6	11	12	19
J kgm ²		0,0020	0,0040	0,0068	0,023	0,031	0,058	0,116	0,125	0,302

The lateral air feeding can be also used in the series 5.5 and 5.6

El disco de alimentación lateral también puede ser usado en las series 5.5 y 5.6.

AIR ROTARY INLET / RACORES GIRATORIOS

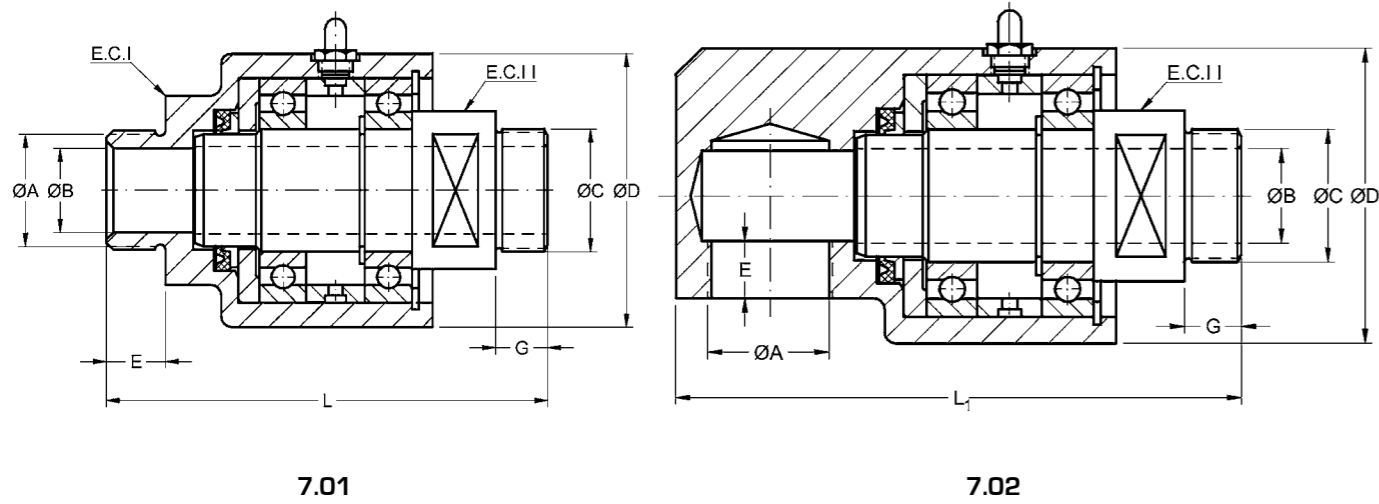

QUICK EXHAUST ACCESSORY / ACCESORIO DE ESCAPE RÁPIDO

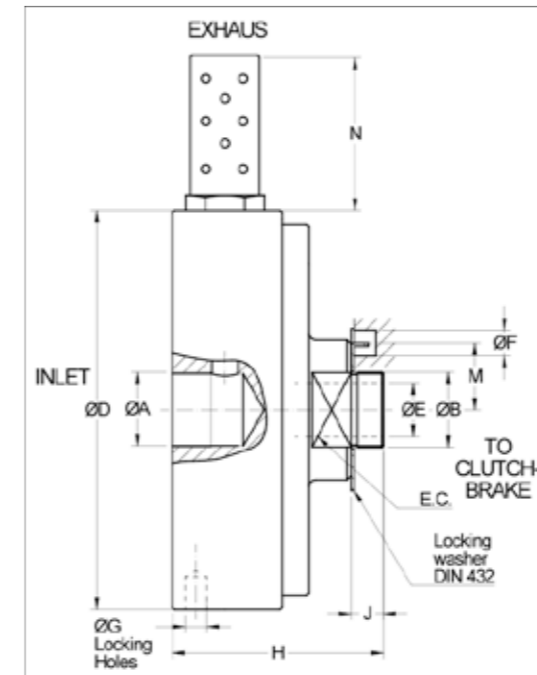

SERIES	7.06					
	02	12	03	04	06	
Ø A	M 22 X 1,5	M 27 x 1,5	M 35 x 1,5	M 50 x 1,5	M 65 x 1,5	
Ø B	M 22 x 1,5	M 27 x 1,5	M 35 x 1,5	M 50 x 1,5	M 65 x 1,5	
Ø D	123	160	185	230	250	
Ø E	13	18	25	36	48	
Ø F	8	9	12	14	19	
Ø G	10.25	10.25	10.25	12.25	12.25	
H	72	91	98	119	134	
I	12	15	15	22	25	
K	14	18	18	18	21	
L	7	9	10	14	14	
M	20	23	31	40	52	
N	45,5	47,5	47,5	45	41,5	
E.C.	32	41	55	75	95	
Weight Kg	1,7	3,8	5,5	9,6	15,7	
Inertia Kgm ²	0,0037	0,0154	0,0293	0,0738	0,214	
For sizes	Series 5.0	60-10	18-36	55-75-76	77-78-79	-
	Series 5.7	50-10	18-25-36	55-75	76-77-78	80
	Series 5.8	23-50-10	18	36-55-75	76-77-78	-

SERIES	7.01 - 7.02						
	00	02	12	03	04	06	
Ø A	R 1/4"	R 1/2"	R 3/4"	R 1"	R 1 1/2"	R 2"	
Ø B	7	13	18	25	38	48	
Ø C	M 14 X 1,5	M 22 X 1,5	M 27 X 1,5	M 35 X 1,5	M 50 X 1,5	M 65 X 1,5	
Ø D	46	62	70	80	100	125	
E	12	12	15	17	22	25	
G	13	12	15	15	22	25	
L	82	95	114	127	165	199	
L ₁	95	111	133	149	198	240	
E.C.I	27	41	46	55	75	95	
E.C.II	17	24	28	32	50	65	
For sizes	Series 5.0, 5.5 y 5.6	-	60-10	18-36	55-75-76	77-78	79-81
	Series 5.7	05-11-16	23-50-10-13	18-19N-25N-36-37N	55-75	76-77-78	80-81-82
	Series 5.8	-	23-50-10	18	36-55-75	76-77-78	80

ASSEMBLY EXAMPLES / EJEMPLOS DE MONTAJE

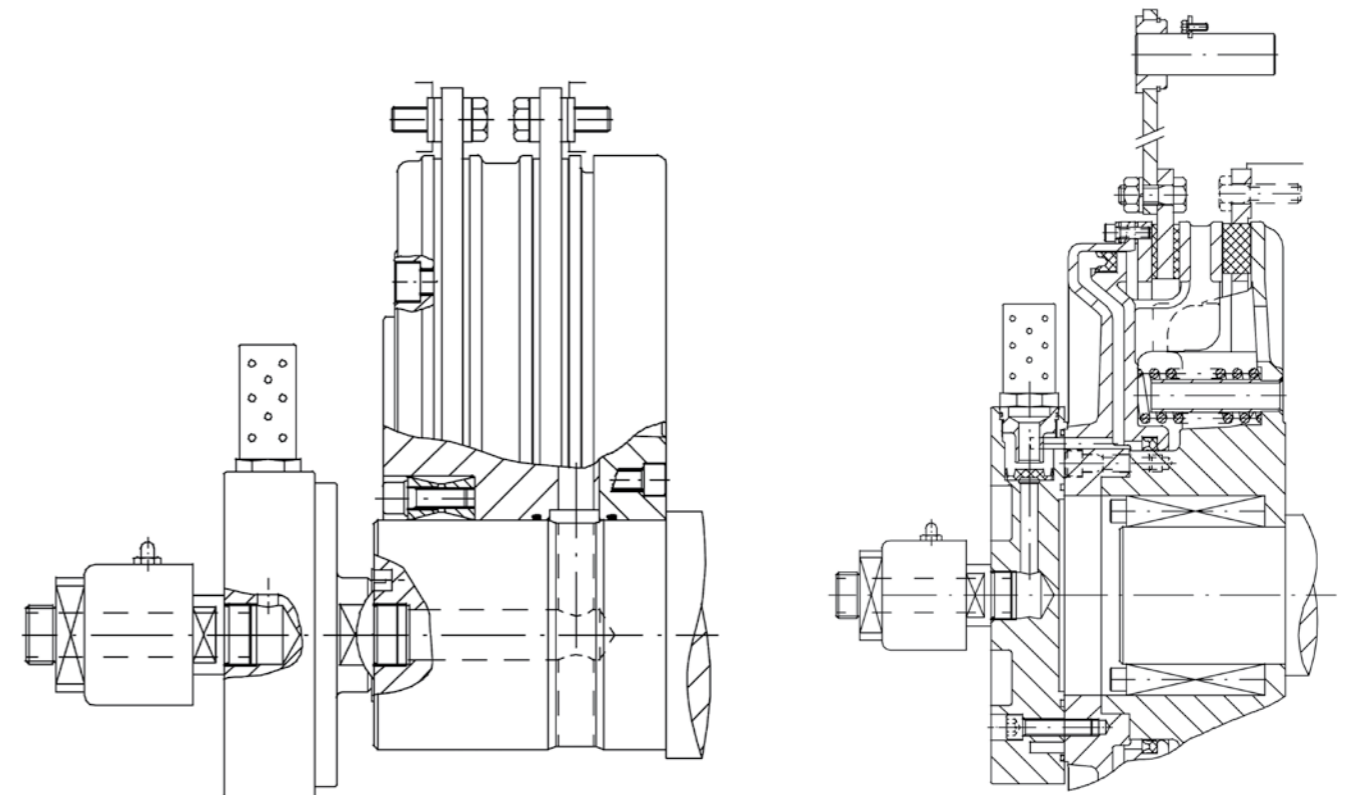

Series 5.35

PNEUMATICALLY ACTUATED MULTI DISC CLUTCHES

EMBRAGUES NEUMÁTICOS MULTIDISCO

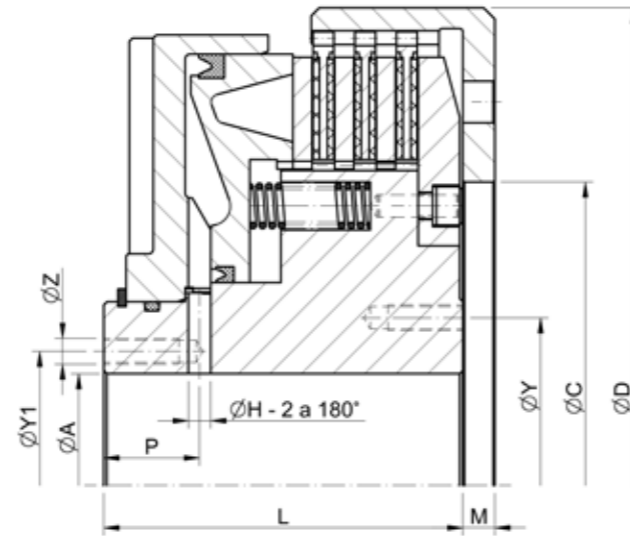

SIZE		16	32	64	90	12	18	36	55	75	76	77	81
Torque	Nm	160	320	640	900	1.280	1.800	3.600	5.500	7.500	10.000	15.000	22.000
Pressure	bar	5,5											
Max speed	min ⁻¹	3.500	3.500	2.800	2.100	2.000	1.900	1.900	1.900	1.500	1.400	1.000	1.000
Weight	Kg	10	12	20	25	32	50	56	72	85	120	300	340
J. int.	Kg m ²	0,019	0,027	0,112	0,140	0,3	0,47	0,5	0,9	1,3	1,8	7	7,5
ext.		0,01	0,012	0,03	0,06	0,15	0,19	0,21	0,25	1,3	1,8	3	4
New vol	dm ³	0,06	0,08	0,12	0,20	0,35	0,70	0,70	1,30	1,40	1,40	2,30	2,50
Max. wear Volum.		0,13	0,20	0,35	0,48	0,85	1,40	1,70	2,40	2,60	3	4	4,50
Ø A	Min.	20	25	30	30	30	50	50	70	70	70	50	100
	Max.	50	50	70	70	90	100	100	130	130	130	150	150
Ø C	Min.	50	50	85	85	100	90	120	180	180	180	200	200
	Max.	110	110	160	160	230	260	260	340	340	340	480	480
Ø D		165	165	225	225	295	345	345	444	444	444	600	600
Ø H		8	8	10	10	10	10	12	14	14	14	14	14
L		80	87	100	110	115	130	140	145	160	167	200	225
M		10	10	10	10	10	15	15	20	20	20	20	2
P		22	22	25	25	30	35	35	40	40	40	60	60
Ø Y ₁		-	-	-	-	110	120	120	146	152	152	186	186
Ø Y		60	60	80	80	110	120	120	180	180	180	210	210
Ø Z	2x180°	M6	M6	M6	M6	M12	M12	M12	M12	M12	M12	M12	M16

Series 5.36

PNEUMATIC SAFETY BRAKES

FRENOS NEUMÁTICOS DE SEGURIDAD

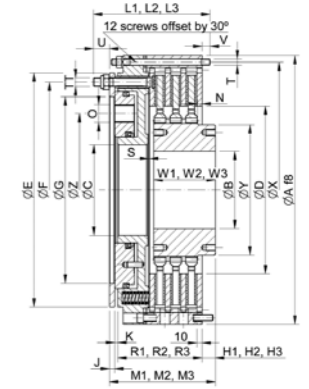

SIZE		05	10	25	30	74	75	76	77	78	79	
Dynamic brake torque Md (Nm)	1 friction disc	4	185	365	710	1310	1820	2830	4240	5550	8080	11110
		3	140	255	535	945	1310	2000	2890	3890	5555	7780
		2	90	185	355	640	910	1415	2120	2830	4040	5555
	2 friction disc	4	365	720	1415	2525	4040	5655	8080	10600	16160	22220
		3	280	510	1055	1890	2780	4445	5890	8330	11670	16670
		2	185	365	675	1265	2020	2830	4240	5350	7880	10700
	3 friction disc	4	535	1110	2020	3840	6060	8080	12625	16160	23230	33330
		3	415	780	1555	2890	4220	6670	8890	12780	17780	24445
		2	265	555	1010	1920	3130	4040	6365	8080	11615	16160
Max speed	min ⁻¹	2800	2240	1700	1450	1250	1120	1000	850	750	670	
Max. stroke Volum.	dm ³	0,052	0,102	0,169	0,34	0,507	0,603	0,66	0,694	1,268	2,23	
J. int.	1 friction disc	Kg m ²	0,004	0,01	0,031	0,069	0,146	0,216	0,451	1,090	1,364	2,615
	2 friction disc		0,008	0,021	0,061	0,134	0,285	0,43	0,819	1,849	2,706	5,207
	3 friction disc		0,009	0,022	0,07	0,165	0,317	0,553	1,04	2,400	4,143	6,531
Weight	1 friction disc	Kg	6,3	10,3	19	30,5	42	56	114	114	161	226
	2 friction disc		9,2	15	27,5	43	60,5	85	146	168	233	329
	3 friction disc		10,1	16,5	30,5	49,5	67	94,5	165	201	277	386
Ø A		195	235	300	360	405	455	505	590	670	740	
Ø B max.		55	75	100	130	155	170	200	225	285	285	
Ø C		66	75	115	130	140	170	170	250	313	325	
Ø D		118	140	185	220	255	285	315	360	440	460	
Ø E		167	200	260	309	354	394	440	507	590	650	
Ø F		156	188	240	286	325	365	405	470	542	592	
Ø G		130	156	205	240	270	320	350	420	490	530	
H 1		11,5	11,5	18	22,25	21,75	17,75	49	22	26,75	32	
H 2		15,00	15,50	18,25	21,75	19,00	17,00	26,00	18,75	27,5	33,00	
H 3		14,5	15	17	20,5	20	19	24,75	23,75	27,5	37,5	
J		4	5	7	10	10	12	15	18	20	20	
G		3,5	3,5	4	4,5	5,5	5,5	5,5	6	7	7,5	
L 1		84,5	95	112	129,25	142,25	156,75	164,5	182,75	212,75	229	
L 2		95	107	117,75	145,00	158,5	173	194	201	239	257,5	
L 3		108,5	122	136	164	182,5	200	223,5	235	272,5	294	
M 1		77,5	86,5	106	122,25	133,5	138,5	168,5	167,25	188	214,5	
M 2		91,5	102	112,25	136,00	148	156	174,5	188,75	215	248,5	
M 3		105	117	129	155	172	183	201,5	222,75	248,5	285	
N		4,5	5	4,5	5	7	8,5	2	9,25	3,5	13,5	
O (3 x 120°)		R 1/8"	R 1/4"	R 1/4"	R 1/2"	R 3/4"	R 1"	R 1"	R 1"	R 1"	R 1 1/4"	
R 1		58	66	77	86,5	97,25	105,25	99	125,75	139,75	159,5	
R 2		69	78	83	101,75	113,5	121,5	125,5	146	160,5	188	
R 3		82,5	93	101	118,75	137,5	148,5	155	180	199,5	224,5	
S (Gap)		0,5	0,5	1	1,2	1,2	1,2	1,2	1,2	1,5	1,5	
TT		M6	M8	M10	M12	M12	M14	M16	M14	M20	M20	
T		M5	M6	M8	M10	M10	M12	M12	M14	M16	M16	
U		12,5	12,5	14	17,5	18,5	21	30	19,5	31,5	26,5	
V		6,5	7,5	10	12	12	15	15	18	20	20	
W 1		32	35	45	52	57	56	82	70	80	90	
W 2		46	50	58	65	72	76	88	97	104	124	
W 3		59	65,5	75	84	95	100	115	128	140	160	
Ø X		185	223	284	340	385	430	480	562	637	708	
Ø Y		75	95	144	160	190	200	245	270	330	330	
Ø Z		114	132,5	180	207	232	270	287	360	430	462,5	

WET CLUTCH-BRAKE SERIES 5.W

FRENO-EMBRAGUES OLEONEUMÁTICO SERIE 5W

This series of clutch-brake is the version of the pneumatic actuated and hydraulically cooled multiplate clutch-brake.

It combines the engagement of the pneumatic clutch-brake, with the cooling capacity of the hydraulic clutch-brakes. As a result, we obtain a clutch-brake with the possibility of a high frequency of engagements.

The disc can be cooled by oil bath, (no external cooling) or by forced cooling (pumped oil circuit) depending on the required dissipation energy of the application.

Éste es el freno-embrague multidisco actuado neumáticamente y refrigerado por aceite.

Esta serie de freno-embrague combina el accionamiento del embrague neumático con la capacidad de refrigeración de los embragues hidráulicos. Como resultado tenemos un frenoembrague con la posibilidad de obtener una alta frecuencia de maniobras.

La refrigeración se produce dependiendo de la energía de disipación requerida por la aplicación, esta refrigeración puede ser forzada por medio de un circuito exterior, para lo cual el freno-embrague está preparado.

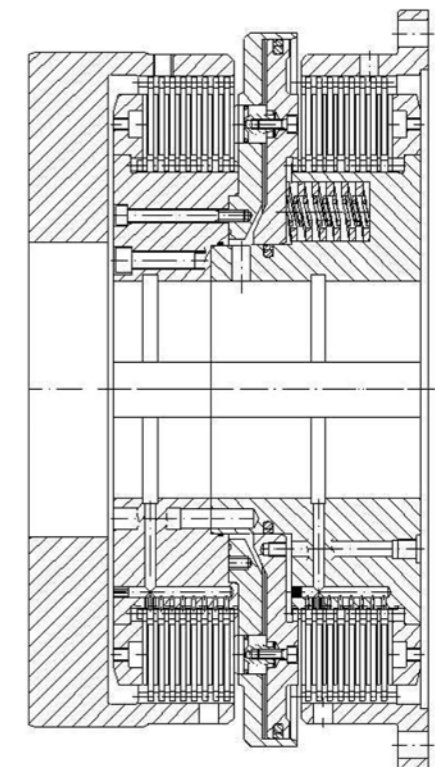

Series 5.W1

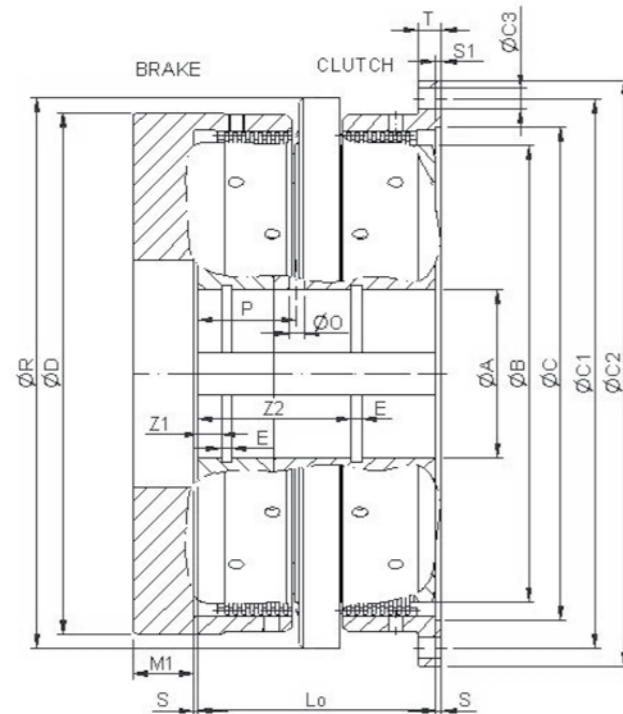

Series 5.W5

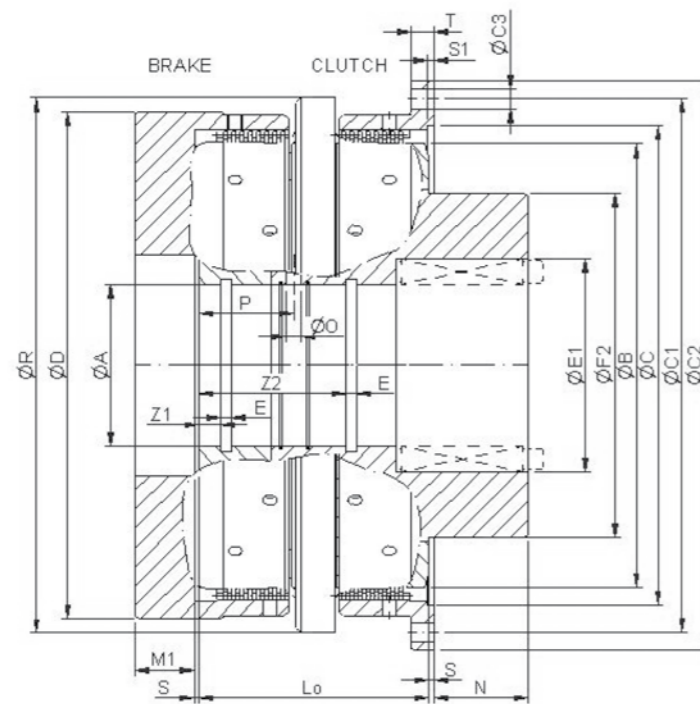

PNEUMATIC CLUTCH-BRAKES / FRENO-EMBRAGUES NEUMÁTICOS

SERIES		5.W1	5.W5	5.W1	5.W5	5.W1	5.W5	5.W1	5.W5	5.W1	5.W5
SIZE		75	77	78	81	82					
DYNAMIC BRAKE TORQUE	Brake side discs= 5	1460	2700	5400	10800	20600					
	Brake side discs= 6	1760	3300	6500	13000	24700					
	Brake side discs= 7	2050	3800	7600	15200	28800					
	Brake side discs= 8	2350	4400	8700	17300	32900					
	Brake side discs= 9	2640	4900	9800	19500	37000					
	Brake side discs= 10	2930	5500	10900	21700	41200					
STATIC CLUTCH TORQUE	Clutch side discs= 5	3270	6300	10000	21300	45900					
	Clutch side discs= 6	3910	7600	12000	25500	54700					
	Clutch side discs= 7	4540	8800	13900	29600	63400					
	Clutch side discs= 8	5150	10000	15800	33600	72000					
	Clutch side discs= 9	5770	11300	17600	37700	80600					
	Clutch side discs= 10	6370	12500	19500	41600	89200					
Max speed	min ⁻¹	1300	1000	850	700	500					
Pressure	bar	5,5									
Weight (8+8 discs)	Kg	91	101	174	202	284	319	530	613	1076	1181
J. int.	Total discs= 10	0,44	0,51	1,13	1,41	2,92	3,48	8,54	10,38	31,31	36,27
	Total discs= 20	0,57	0,64	1,47	1,75	3,75	4,31	10,87	12,71	40,38	45,33
Weight (8+8 discs)	dm ³	0,25	0,47	0,77	1,38	2,77					
Ø A	min.	70	80	105	120	160					
	max.	95	115	150	180	250					
Ø B		260	320	390	490	630					
Ø C (H7)		277	350	415	530	670					
Ø C ₁		310	400	470	590	750					
Ø C ₂ (g7)		330	425	500	630	800					
Ø C ₃	12 x 30°	11	13,5	17,5	22	26					
Ø D		296	380	440	560	710					
E		8	12	12	12	15					
E ₁ max.		135	155	200	235	305					
F ₂		200	250	300	380	475					
Lo	Total discs= 10	131	136	176	204	270					
	Total discs= 12	143	149	192	222	294					
	Total discs= 14	155	162	208	240	318					
	Total discs= 16	167	175	224	258	342					
	Total discs= 18	179	188	240	276	366					
	Total discs= 20	191	201	256	294	390					
M ₁		40	50	60	65	75					
N		70	108	116	132	174					
Ø O	2 x 180°	8	10	13	16	20					
P	Brake side discs= 5	46	48,5	64	78	106					
	Brake side discs= 6	52	55	72	87	118					
	Brake side discs= 7	58	61,5	80	96	130					
	Brake side discs= 8	64	68	88	105	142					
	Brake side discs= 9	70	74,5	96	114	154					
	Brake side discs= 10	76	81	104	123	166					
R		311	388	468	592	755					
S		5	5	5	5	5					
S ₁		6	6	6	6	6					
T		12	16	20	25	30					
Z ₁		14	14,5	26,5	24	32					
Z ₂	Brake side discs= 5	91	96,5	129	141	186					
	Brake side discs= 6	97	103	137	150	198					
	Brake side discs= 7	103	109,5	145	159	210					
	Brake side discs= 8	109	116	153	168	222					
	Brake side discs= 9	115	122,5	161	177	234					
	Brake side discs= 10	121	129	169	186	246					

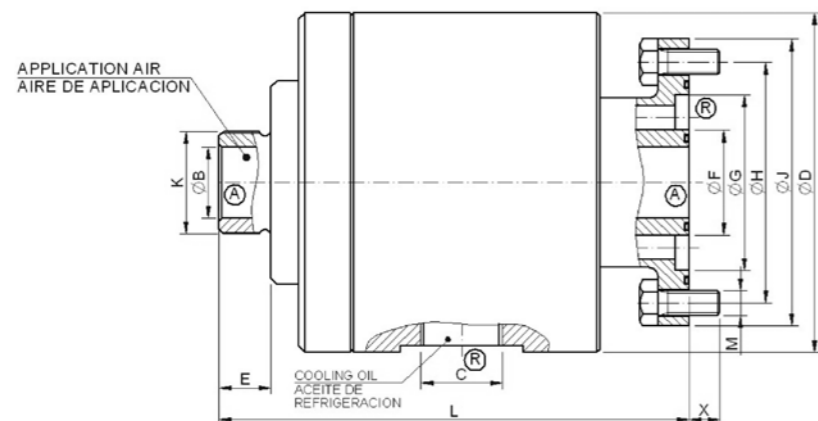

SERIES	7.07.12.908	7.07.03.912	7.07.04.909
Ø B	14	23	32
E	1/2"Gas	3/4"Gas	1"Gas
Ø D	90	110	136
E	15	17	22
Ø F	26	34	43
Ø G	44	57	72
Ø H	64	78	100
Ø J (g6)	75	93	118
K	3/4"GAS	1"GAS	1 1/2"GAS
L	140	153	184
M	M6 (4x90°)	M8 (4x90°)	M10 (4x90°)
X	10	10	16
For sizes	75-77	78-81	82

ASSEMBLY EXAMPLE / EJEMPLO DE MONTAJE

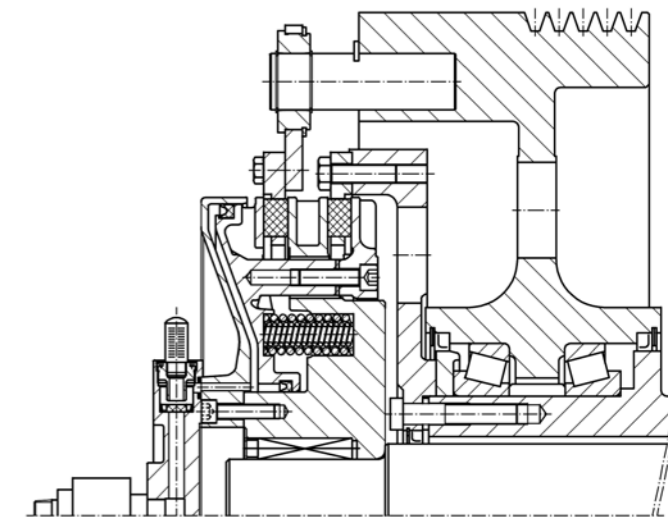
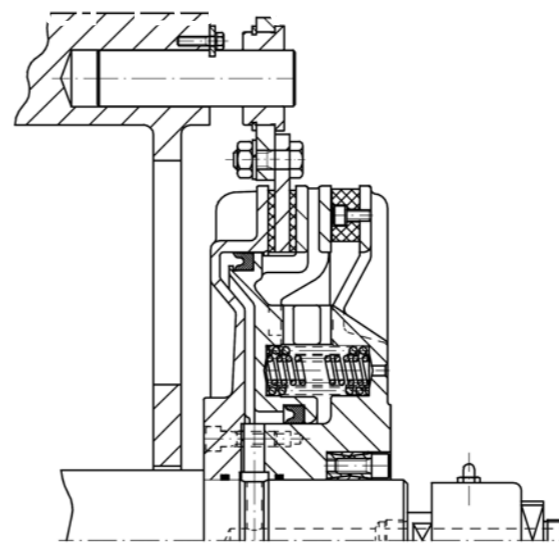
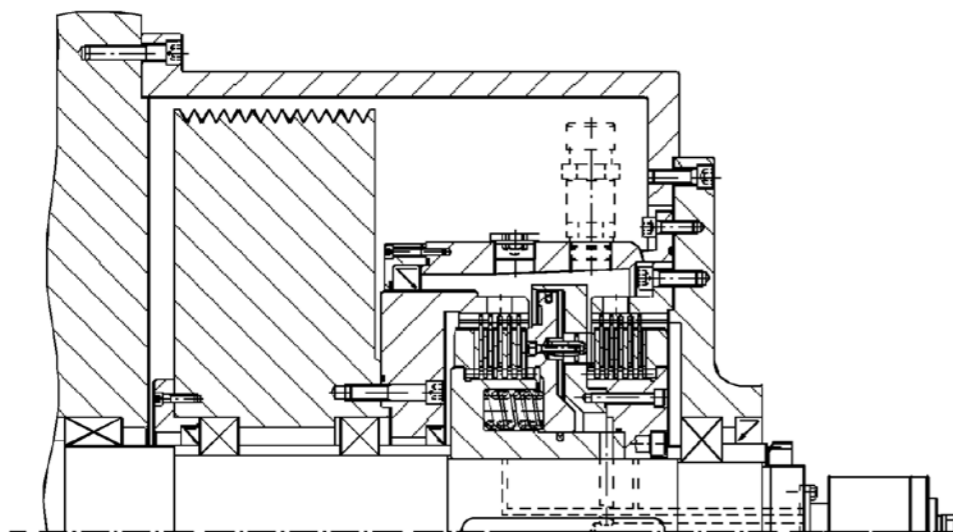

Only brake version. It is in fact a safety pneumatic brake.

Versión solo freno. Es en realidad un freno neumático de seguridad.

Clutch-brake unit with quick exhaust. To get very quick braking response time.

Freno-embrague con escape rápido. Se consiguen tiempos de respuesta en frenada considerablemente bajos.

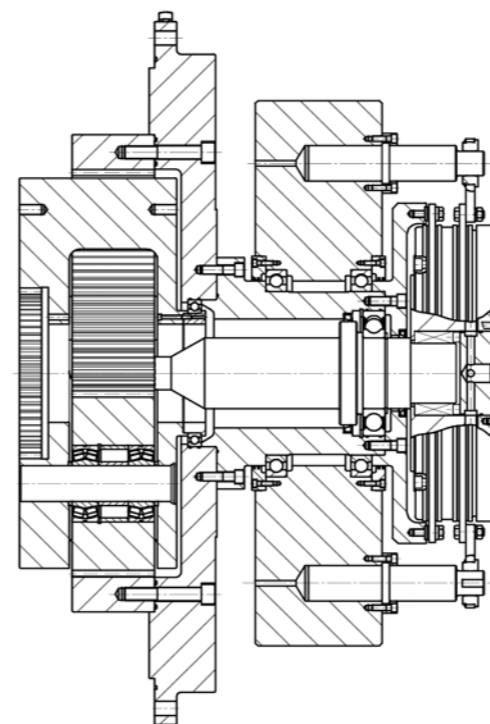

Clutch-brake with planetary gear.

Freno-embrague con reductor planetario.

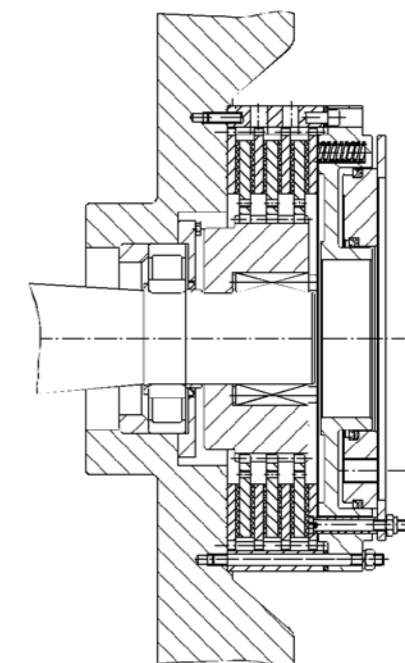

Pneumatic safety brake.

Freno neumático de seguridad.

**QUESTIONNAIRE FOR PRESSES /
CUESTIONARIO PARA PRENSAS**

DATE / FECHA _____

GOIZPER	<u>Data form for mechanical presses CL-BR unit selection</u> Datos para la selección de freno-embragues para prensas	
CUSTOMER / Cliente _____ Responsible / Responsable _____ Dpt./ Dpto: _____ Phone / Teléfono _____ E-mail: _____		
<u>Characteristics of the press:</u> Características de la prensa	Type / Tipo _____ Single Stroke / Golpe a golpe <input type="checkbox"/> Continuous run./ en continuo <input type="checkbox"/>	Model / Modelo _____
<u>CL-BR mounting:</u> Montaje del F-E:	End of the shaft / Extremo del eje _____ Between frame and flywheel / Entre bastidor y volante _____	<input type="checkbox"/> <input type="checkbox"/>
<u>Type of CL-BR unit required:</u> Tipo de F-E solicitado	Pneumatically actuated / Neumático <input type="checkbox"/> Hydraulically actuated / Hidráulico <input type="checkbox"/>	<input type="checkbox"/> <input type="checkbox"/>
<u>TECHNICAL DATA OF THE PRESS / Datos técnicos de la prensa</u>		
1. Max force of the press. _____ Fuerza máxima de la prensa	F = _____ kN	
2. Crankshaft radius _____ Radio de la excéntrica	r = _____ mm	
3. Side rod length _____ Longitud de la biela	L = _____ mm	
4. Working angle before B.D.C. _____ Ángulo de trabajo antes del P.M.I.	α = _____ °	
Or effective working length _____ Ó altura efectiva de trabajo	h = _____ mm	
Or working length _____ Ó altura de trabajo	s = _____ mm	
5. Crankshaft max speed _____ Revoluciones max del eje de la excéntrica	n_c = _____ min ⁻¹	
6. CL-BR max speed _____ Revoluciones max del F-E trabajando golpe a golpe	n_c = _____ min ⁻¹	
7. Moment of inertia of all the masses to be braked, reduced to the cl-br shaft [CL-BR inertia excluded] Momento de inercia de las masas a frenar reducido al eje del F-E (ex. inercia del F-E)	J_m = _____ kg m ²	
8. Delay of relay and valve _____ Tiempo de respuesta del mando y válvula	t_r = _____ sg	
9. Number of engagements per minute at max. speed, working at single stroke. _____ Nº de maniobras/min requeridas trabajando golpe a golpe a rpm max.	N = _____ min ⁻¹	
<u>BRAKING VALUES / Valores de frenado</u>		
10. Max.tot.braking angle req. in the crankshaft [delay of relay and valve incl.] _____ Ángulo de frenado total max requerido en el eje de excéntrica [incl. tiempo de mando]	α_{fe} = _____ °	
11. Max total braking time required [delay of relay and valve included] _____ Tiempo de frenado máximo requerido [considerando el tiempo de mando]	t_f = _____ sg	

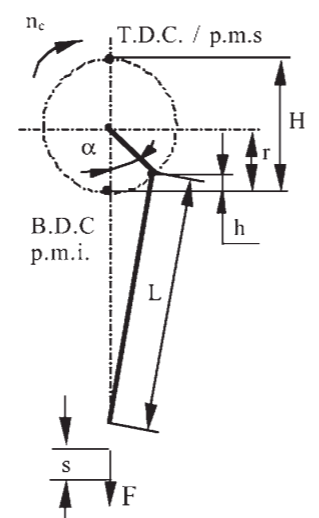

**QUESTIONNAIRE FOR APPLICATIONS IN GENERAL /
CUESTIONARIO PARA APLICACIONES EN GENERAL**

DATE / FECHA _____

GOIZPER	<u>Data form for CL-BR unit selection</u> Datos para la selección de freno-embragues	
CUSTOMER / Cliente _____ Responsible / Responsable _____ Dpt./ Dpto: _____ Phone / Teléfono _____ E-mail: _____		
Type of CL-BR unit required / Tipo de freno-embrague solicitado: Pneumatic / Neumático: <input type="checkbox"/> Hydraulic / Hidráulico: <input type="checkbox"/> Electromagnetic / Electromagnético: <input type="checkbox"/> Mechanic / Mecánico: <input type="checkbox"/>		
Machine Type / Tipo de máquina: _____ Drive machine / Máquina motriz: Type / Tipo: Electric Motor / Motor eléctrico: <input type="checkbox"/> Combustion engine / Motor de combustión: <input type="checkbox"/> Hydraulic motor / Motor hidráulico: <input type="checkbox"/> Other / Otro: _____		
Power / Potencia P = _____ Kw Speed / Velocidad: n = _____ min ⁻¹ Reduction to CL-BR / Reducción al freno embrague: _____		
Mounting / Montaje: Rotary axis / Eje de rotación: Horizontal: <input type="checkbox"/> Vertical: <input type="checkbox"/>		
CL-BR situation / Situación de freno-embrague: Exposed / Expuesto: <input type="checkbox"/> Closed housing / Alojamiento cerrado: <input type="checkbox"/> Shaft diameter / Diámetro de ejes: Driver side / Parte conductora: _____ mm. Driven side / Parte conducida: _____ mm.		
Required torque on clutches or brakes / Par necesario en el freno-embrague: Engaging dynamic torque / Par de accionamiento dinámico: M_s = _____ Nm Transmissible static torque / Par estático transmisible: M_t = _____ Nm Curve or value of load torque / Curva o valor del par de carga: M_L = _____ Nm		
Operating conditions at engagement / Condiciones del accionamiento: Stationary / Estático: <input type="checkbox"/> Full load / Plena carga: <input type="checkbox"/> Without load / Sin carga: <input type="checkbox"/> Initial driver speed / Velocidad inicial del conductor: n_{10} = _____ min ⁻¹ Initial driven speed / Velocidad inicial del conducido: n_{20} = _____ min ⁻¹ Max. Speed / Velocidad máxima: n_{max} = _____ min ⁻¹		
Moments of inertia reduced to CL-BR / Momento de inercia reducido al freno-embrague: Drive side / Parte conductora: J_A = _____ kgm ² Driven side / Parte conducida: J_L = _____ kgm ²		
Times / Tiempos: Braking time / Tiempo de frenada: t_3 = _____ s Clutching time / Tiempo de embragado: t_3 = _____ s		
Operating frequency / Frecuencia de accionamiento: N = _____ min ⁻¹		

GOIZPER

● GOIZPER GROUP

Antigua, 4
20577 Antzuola
Gipuzkoa - Spain

Tel: + 34 943 78 60 00
goizper@goizper.com

● GOIZPER FRANCE

Espace d'Activités Becquerel
15, Avenue Henri Becquerel
51000 Châlons en Champagne
France

Tel: + 33 (0)3 26 21 08 39
goizperfrance@goizper.com

● GOIZPER GmbH

Bevertalstr. 20
42499 Hückeswagen
Deutschland

Tel.: +49 (0) 2192 935 99 03
goizperdeutschland@goizper.com

● GOIZPER TRANSMISSION MACHINERY
(WUXI) CO., LTD.

No. 3 Workshop, Fengneng Road,
Wind Power Science & Technology
Industrial Park,
Huishan Economic Development Zone,
214174 Wuxi, Jiangsu - China

Tel: +86 186 217 020 36
goizperchina@goizper.com

 **Goizper Group**
Growing through cooperation

www.goizper.com